

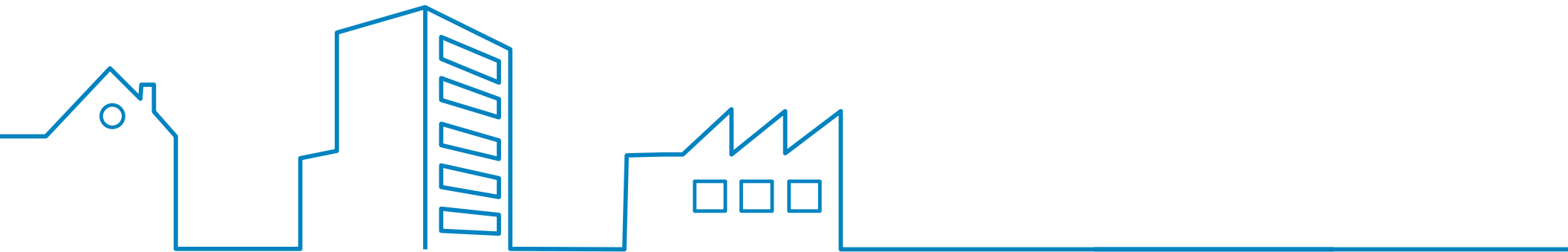

Daikin Altherma Heat pump convector

2nd Generation
FWXV/FWXM/FWXT Series



Daikin Altherma Heat pump convector pre-sales package October 2022

New in this version:

- Modbus explained
- Q&A
- Minor changes

CONTENT

Level 1

1. Aim of development
2. Concept
3. The product range
4. Features and benefits
5. Summary

Level 2

1. Specifications
2. Details of speed setting for modulating mode
3. Physical positions and options
4. Controls and control options
5. MODbus explained
6. Electrical Diagrams
7. Product naming
8. Manuals
9. Country compliance
10. Spare parts
11. Competitive landscape
12. Q&A
13. Annexes

1.1. Aim of development

Aim of development: Heat pump convector

Why?

Growing demand for fast emitter systems for heating and cooling operation in residential buildings
More stringent climate conditions also show cooling demand in Western European areas where this was non-existing before

How?

Efficiency at the highest level (DC inverter fan fully 100% modulation)
Very quiet operation and modern design for residential installation

What?

Daikin Altherma Heat pump convector: The new benchmark in performance and design

1.2. Concept

Concept: Intuitively beautiful

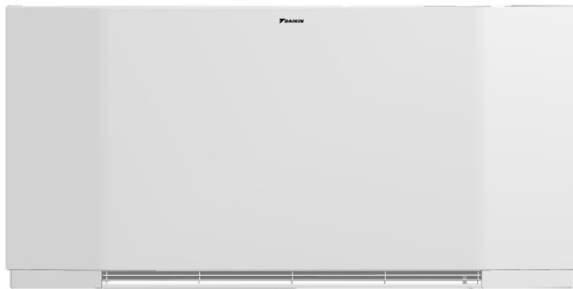

Stylish new design

Ultra quiet operation for
ultimate comfort

Space heating

Perfect fit for heat pumps at 35°C LWT

Provides cooling

Fast reacting high-capacity cooling

7 *The images shown are renderings. Color of the unit is RAL9003*



1.3. The product range

Range and operation

Application	Type/Size	10	15	20
Low wall	FWXV*ABTV3(R)	√	√	√
Built-in wall	FWXM*ATV3(R)	√	√	√
High wall	FWXT*ABTV3(L)	√	√	√
High wall + IR control	FWXT*ABTV3C(L)	√	√	√

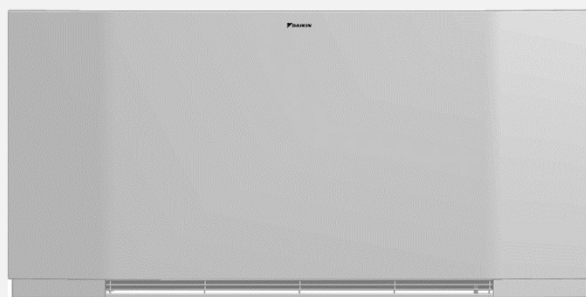

Low wall



Built-in wall



High wall (+ IR Control)

Sizes (Low wall FWXV)



Sizes (Built-in wall FWXM)

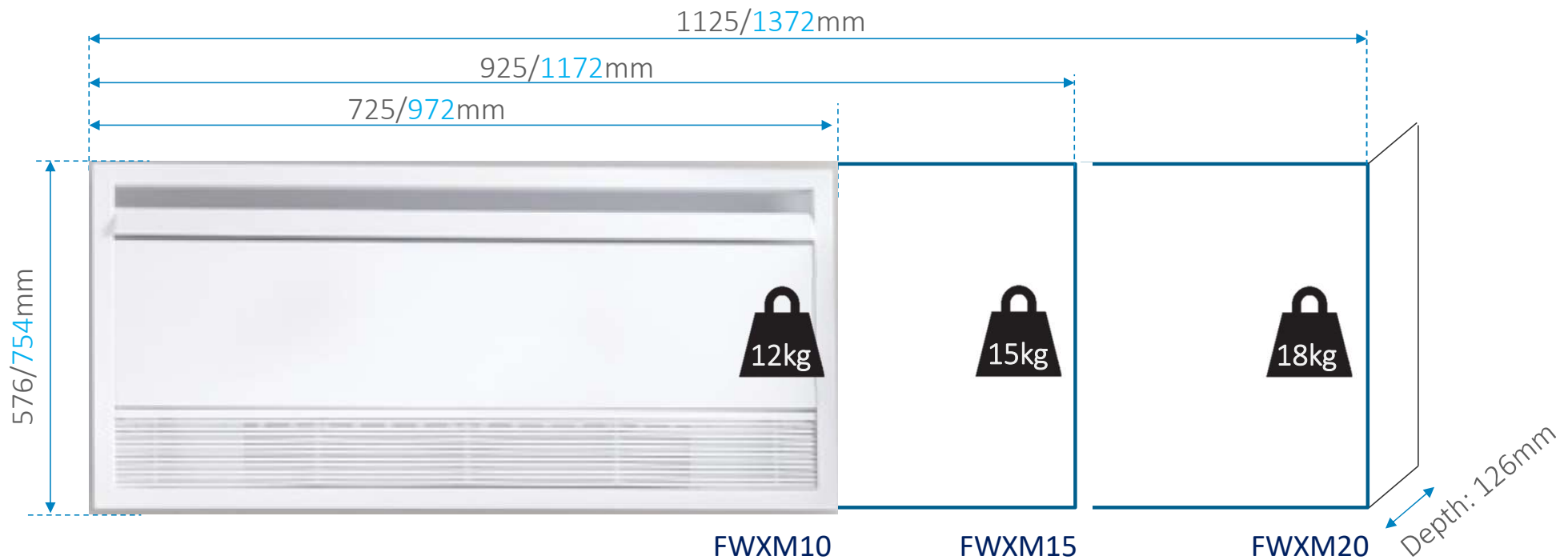

Sizes in grey are for the internal unit. Weights are for the internal unit.
Sizes in blue are for the cover.

Sizes (High wall FWXT-(C))

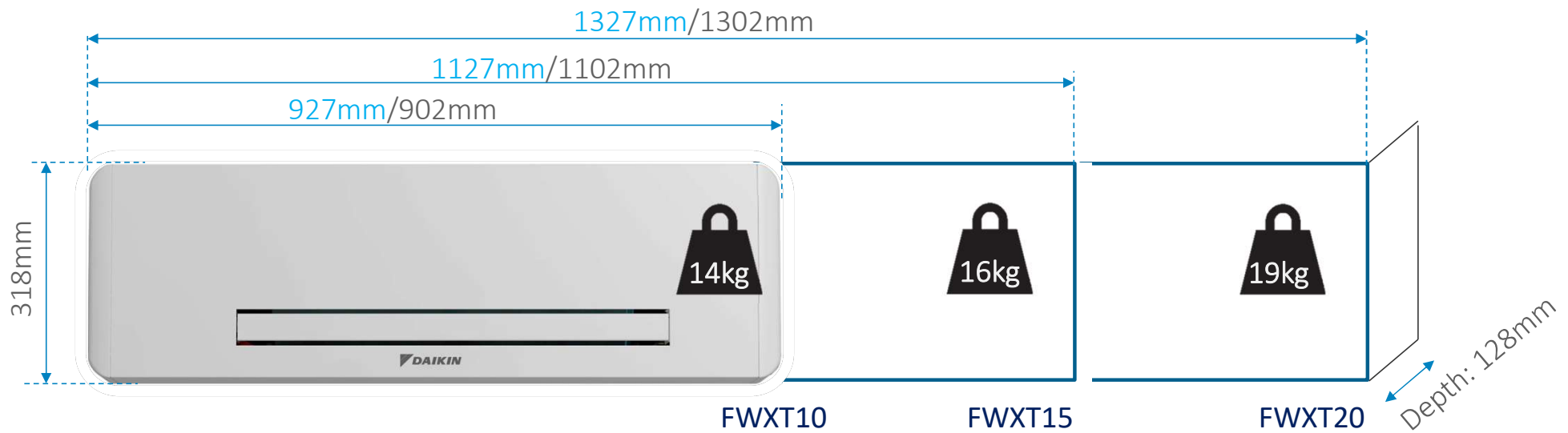

Sizes in grey are for wall space needed.
Sizes in blue are for the cover.

1.4. Features and benefits

Features and benefits: for the installer

Application area's



- New build NZEB homes
- Renovation projects



Possible combination with UFH



- Small businesses
- Office spaces



- Collective apartments
- Co-housing projects



Possible combination with Low enthalpy heat net

Features and benefits: for the installer

Application area's



- New build NZEB homes
- Renovation projects



Possible combination with UFH

New build



- New build NZEB building have very low heat demand
 - Fast emitter ensures comfort and eliminates overheating during summer
 - Modulating fan ensures optimal energy usage
 - Low temperature regime enables heat pump combination
 - Combinable with UFH due to similar temperature regime
 - No more mixing station! No more energy losses

Renovation



- Perfect fit for renovations
 - Easy and flexible installation
 - *No need to put UFH piping to have optimal Heat pump usage*
 - *High capacity*
 - *Save space by replacing the existing radiator system*

Features and benefits: for the user

High performance

*High performant DC inverter fan
Fully modulating or 3 step control*



*High performance heat exchanger
Leading edge efficiency*

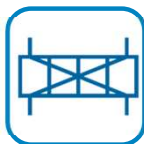

*Super silent unit
Sound pressure down to 25dB(A)*

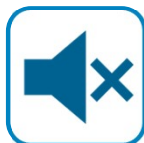

*Fast reactive emitter system
Ensuring comfort and eliminating overheating*

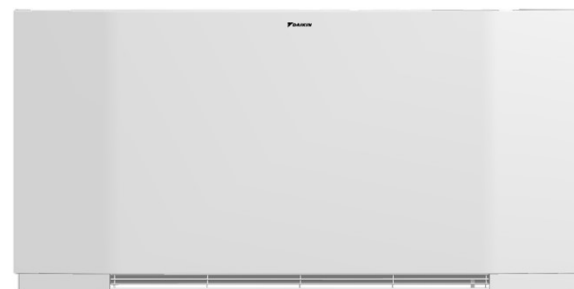

Features and benefits: for the user

Extra quiet

Sound pressure at 1m down to less than 25dB(A)

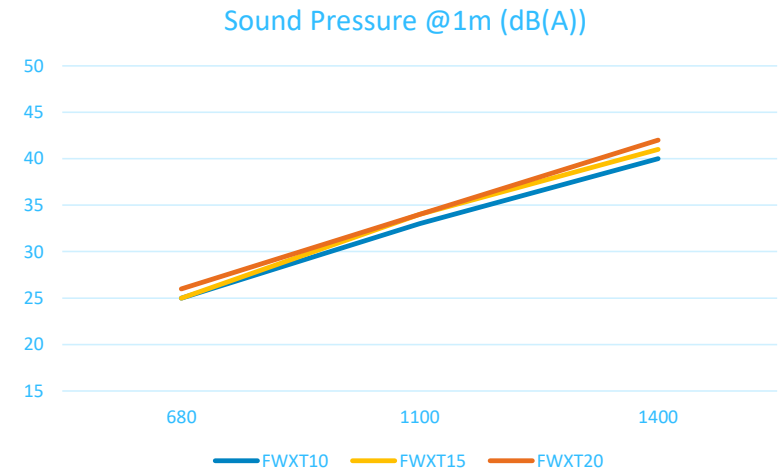
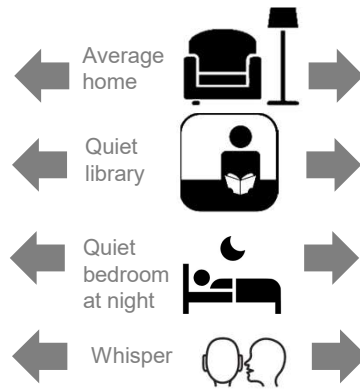
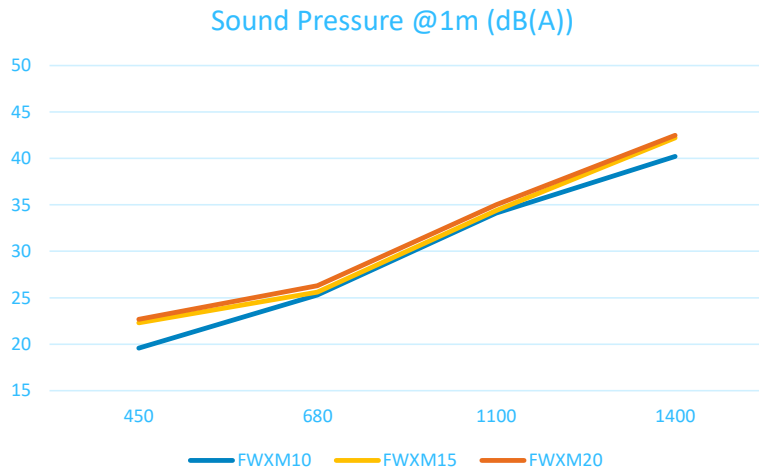

Features and benefits: for the user

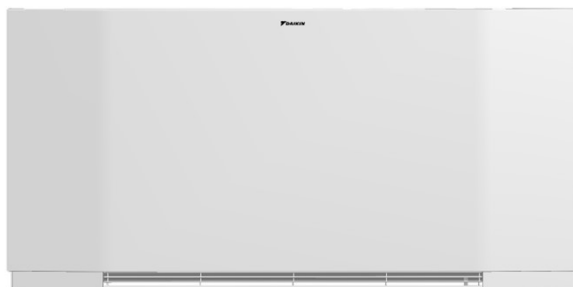
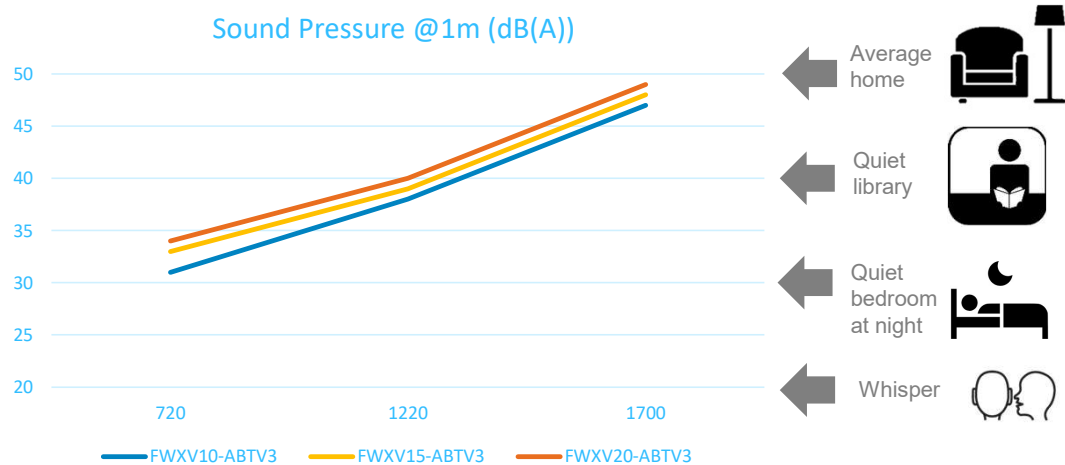

Features and benefits: for the user



Extremely quiet operation

Sound pressure level down to 25 dBA @ 1m

As the unit reaches its set point, a continuous modulating fan gradually reduces its speed and creates less noise.

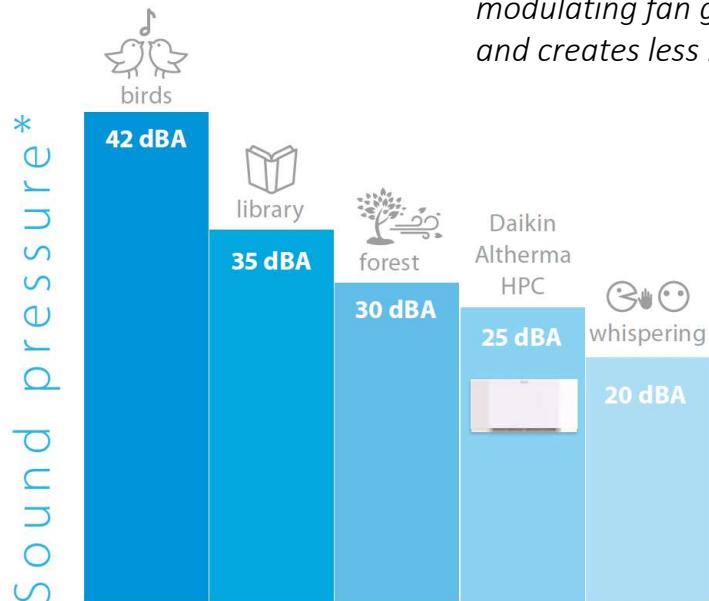

*at 1 meter.



Features and benefits

Premium design



Stylish outlook

Perfectly integrated in modern homes



Engineered design

Beautiful design but keeping practical accessibility



Features and benefits: for the user

High heating capacity (FWXV)

Very fast reactive system ensures comfort and reduces heating times.

The silent modulating fan saves space compared to convectional radiators

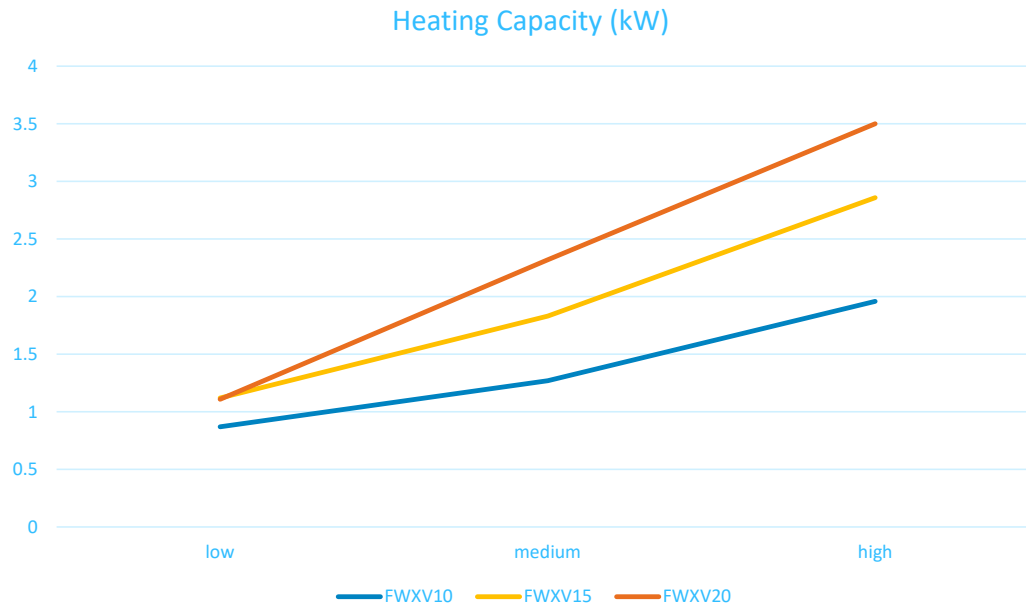

at 45°C/40°C regime



Features and benefits: for the user

High heating capacity (FWXM)

Very fast reactive system ensures comfort and reduces heating times.

The silent modulating fan saves space compared to convectional radiators

Heating Capacity (kW)

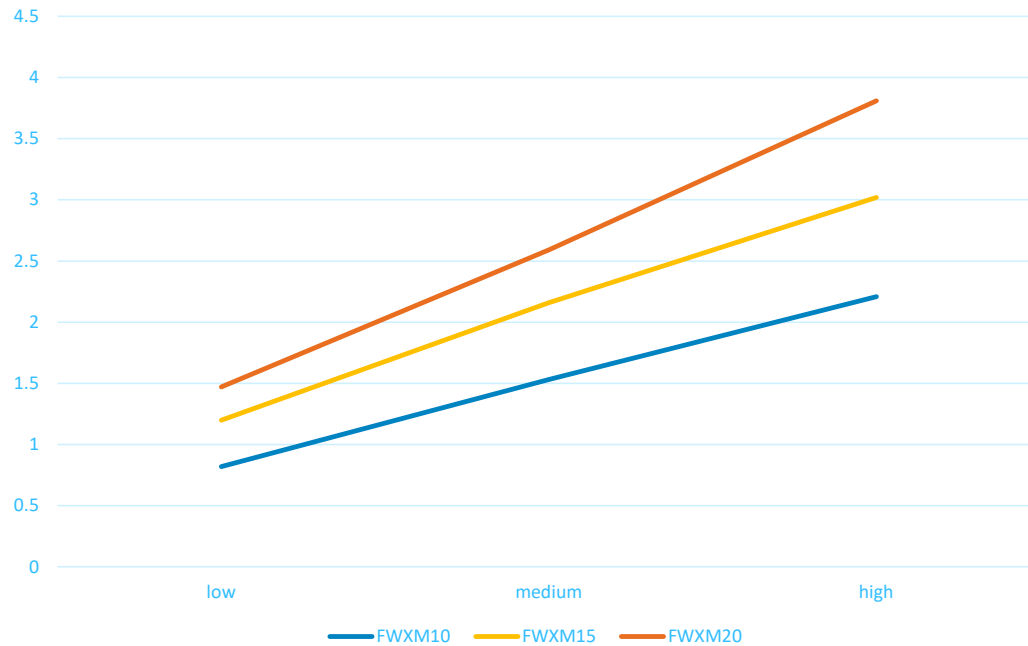

at 45°C/40°C regime



Features and benefits: for the user

High heating capacity (FWXT)

Very fast reactive system ensures comfort and reduces heating times.

The silent modulating fan saves space compared to convectional radiators

Heating Capacity (kW)

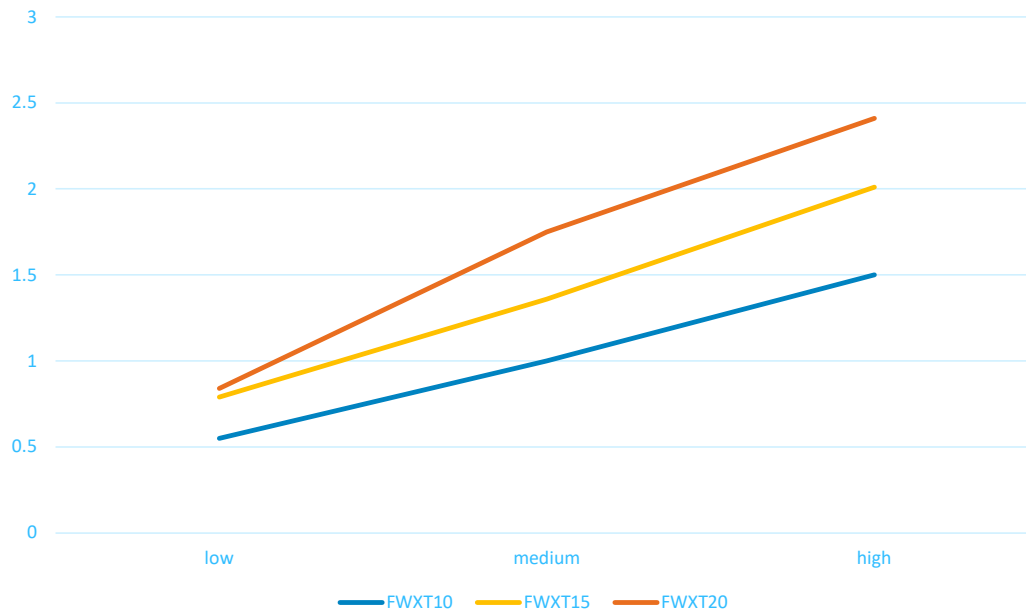

at 45/40°C regime



Features and benefits: for the user

High cooling capacity (FWXV)

*Having a fast emitter ensures immediate comfort in high insulated houses
And directly prevents overheating.*

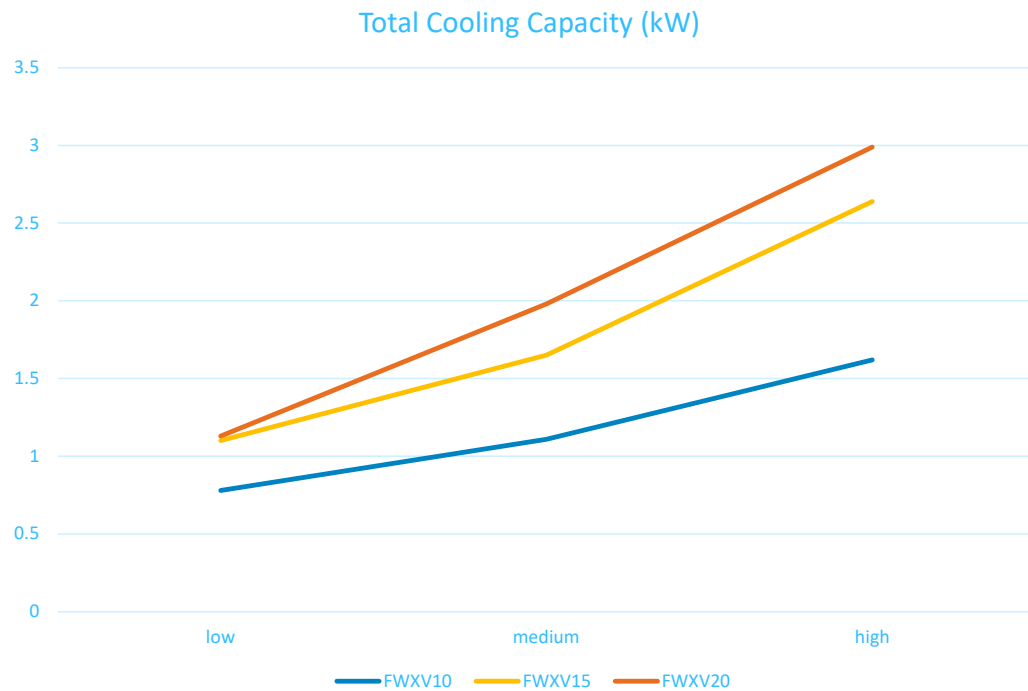

at 7/12°C regime



Features and benefits: for the user

High cooling capacity (FWXM)

*Having a fast emitter ensures immediate comfort in high insulated houses
And directly prevents overheating.*

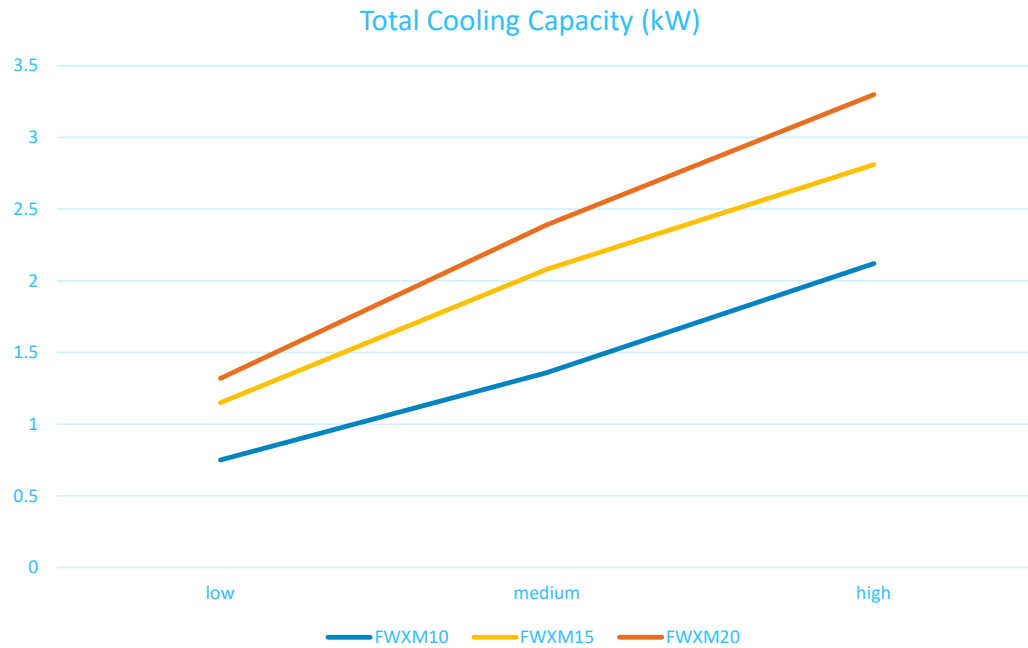

at 7/12°C regime



Features and benefits: for the user

High cooling capacity (FWXT)

*Having a fast emitter ensures immediate comfort in high insulated houses
And directly prevents overheating.*

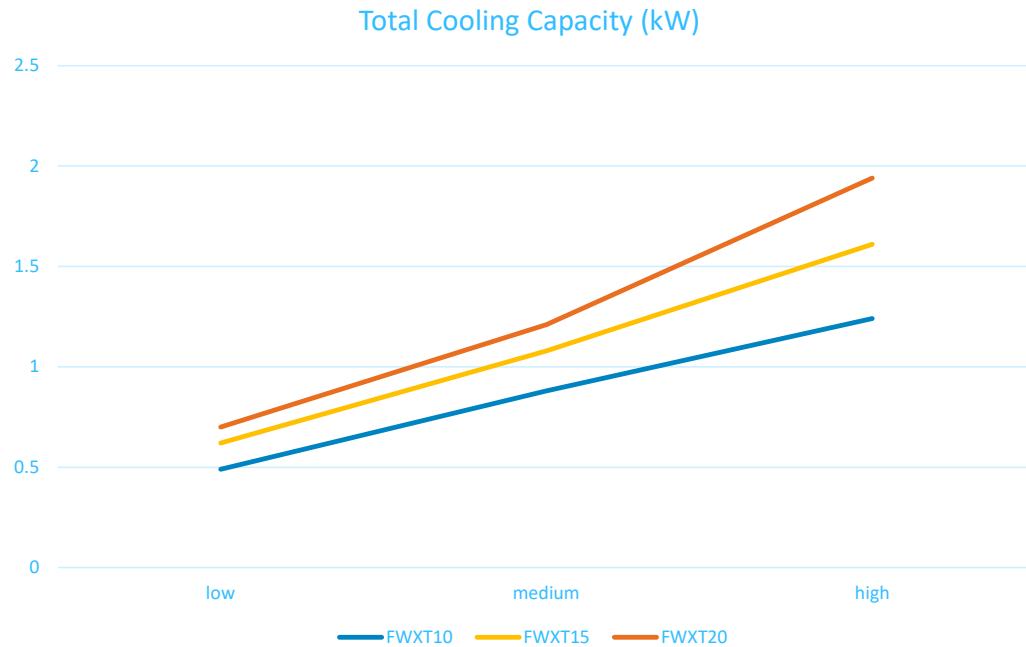

at 7/12°C regime



1.5. Summary

Selling points

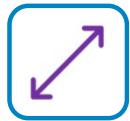

Extended range

24 models with 3 capacity classes



Engineered design

Beautiful design but keeping practical accessibility



Remarkably slim

Only 135mm in width floor standing
Only 128mm in width high-wall



High heating capacity

Possible to choose 30/35°C regime



Fast reactive emitter

Continuous comfort and no overheating in summer



Space cooling

Active cooling with high efficiency



Easy, trouble-free installation

Straight forward piping, wiring and configuration



Extremely quiet operation

Sound pressure level down to 25 dBA @ 1m

2.1. Specifications

Specifications: Capacity and sound (FWXV)



		FWXV10ABTV3(R)	FWXV15ABTV3(R)	FWXV20ABTV3(R)
Heating capacity (2)	Min. kW	0,87	1,12	1,11
	Med. kW	1,27	1,83	2,32
	Max. kW	1,96	2,86	3,5
Cooling capacity (1)	Min. kW	0,78	1,1	1,13
	Med. kW	1,11	1,65	1,98
	Max. kW	1,62	2,64	2,99
Sensible cooling capacity (1)	Min. kW	0,58	0,82	0,85
	Med. kW	0,71	1,15	1,55
	Max. kW	1,25	1,91	2,33
Sound power level	Min. dBA	40	42	43
	Med. dBA	47	49	50
	Max. dBA	56	57	58
Sound pressure level (3)	Min. dBA	31	33	34
	Med. dBA	38	39	40
	Max. dBA	47	48	49

- High heating capacity at low sound pressure
- Capacity level with corresponding sound power and sound pressure level.



Note

(1) At 7/12°C regime

(2) At 45/40°C regime

(3) ISO7779 @1m

Specifications: Capacity and sound (FWXM)



		FWXM10AATV3(R)	FWXM15AATV3(R)	FWXM20AATV3(R)
Heating capacity (2)	Min. kW	0,82	1,2	1,47
	Med. kW	1,53	2,16	2,59
	Max. kW	2,21	3,02	3,81
Cooling capacity (1)	Min. kW	0,75	1,15	1,32
	Med. kW	1,36	2,08	2,39
	Max. kW	2,12	2,81	3,3
Sensible cooling capacity (1)	Min. kW	0,59	0,83	1,02
	Med. kW	1,07	1,51	1,84
	Max. kW	2,11	2,11	2,71
Sound power level	Min. dBA	35	36	36
	Med. dBA	45	46	47
	Max. dBA	53	54	55
Sound pressure level (3)	Min. dBA	25	26	26
	Med. dBA	34	34	35
	Max. dBA	40	42	42

- High heating capacity at low sound pressure
- Capacity level with corresponding sound power and sound pressure level.



Note

(1) At 7/12°C regime

(2) At 45/40°C regime

(3) ISO7779 @1m

Specifications: Capacity and sound (FWXT)



			FWXT10ABTV3(C)(L)	FWXT15ABTV3(C)(L)	FWXT20ABTV3(C)(L)
Heating capacity (2)	Min.	kW	0,55	0,79	0,84
	Med.	kW	1	1,36	1,75
	Max.	kW	1,5	2,01	2,41
Cooling capacity (1)	Min.	kW	0,49	0,62	0,7
	Med.	kW	0,88	1,08	1,21
	Max.	kW	1,24	1,61	1,94
Sensible cooling capacity (1)	Min.	kW	0,37	0,52	0,57
	Med.	kW	0,7	0,86	1,02
	Max.	kW	0,98	1,27	1,52
Sound power level	Min.	dBA	35	36	37
	Med.	dBA	46	47	48
	Max.	dBA	53	54	55
Sound pressure level (3)	Min.	dBA	25	25	26
	Med.	dBA	33	34	34
	Max.	dBA	40	41	42

- High heating capacity at low sound pressure
- Capacity level with corresponding sound power and sound pressure level.



Note

(1) At 7/12°C regime

(2) At 45/40°C regime

(3) ISO7779 @1m

Specifications: Water flow rate/ Water pressure drop



		FWXV10AATV3	FWXV15AATV3	FWXV20AATV3	
Heat exchanger	Quantity	1	1	1	
	Internal coil volume	l	0,8	1,13	1,46
		bar	10	10	10
Water circuit	Piping connections diameter	inch	¾	¾	
	Piping material	type	EUROKONUS	EUROKONUS	EUROKONUS
	Heating - Water pressure drop (2)	kPa	1,3	8,6	3,8
		kPa	4,2	3,3	11,2
		kPa	7,2	11,5	21,3
	Cooling - Water pressure drop (1)	kPa	1,2	4,3	2,1
		kPa	2,8	19,3	13,1
		kPa	2,9	27	24
	Heating - Water flow rate (2)	kg/h	163,5	212,5	327
		kg/h	280,3	401,1	524,6
		kg/h	374,1	534,5	667,5
	Cooling - Water flow rate (1)	kg/h	113,5	223,7	313
kg/h		234,1	371,7	433,6	
kg/h		303,6	496,6	550,6	
Max. Pressure	bar	10	10	10	



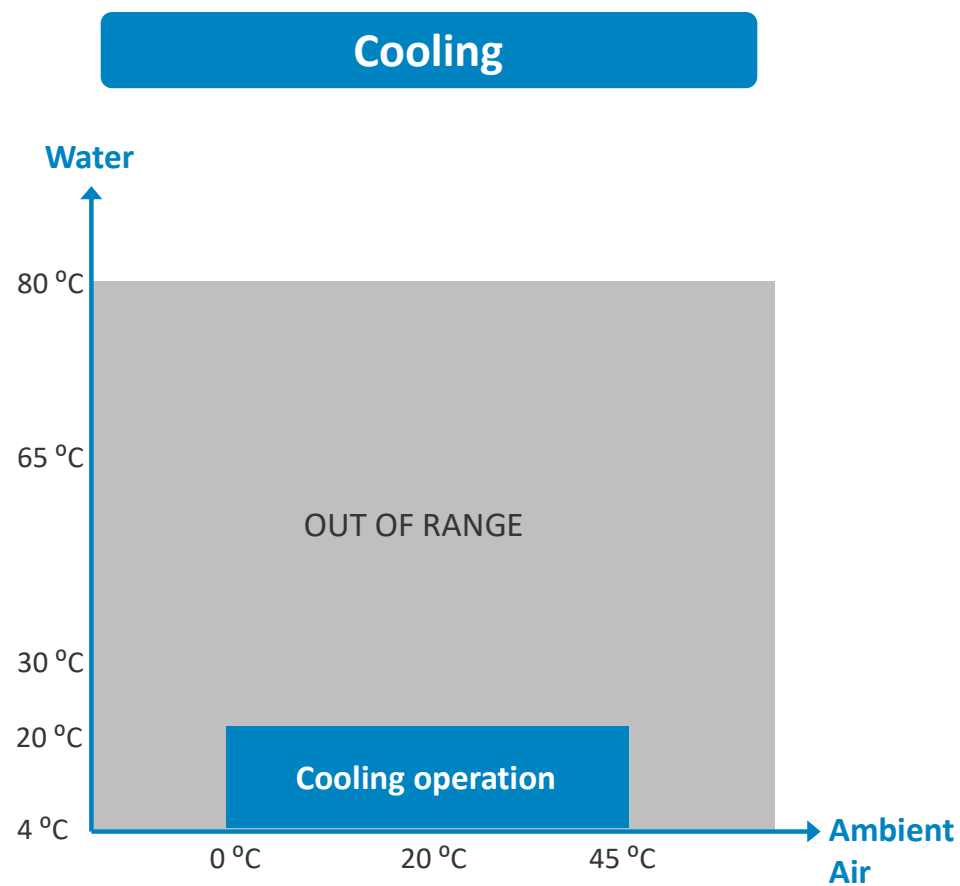
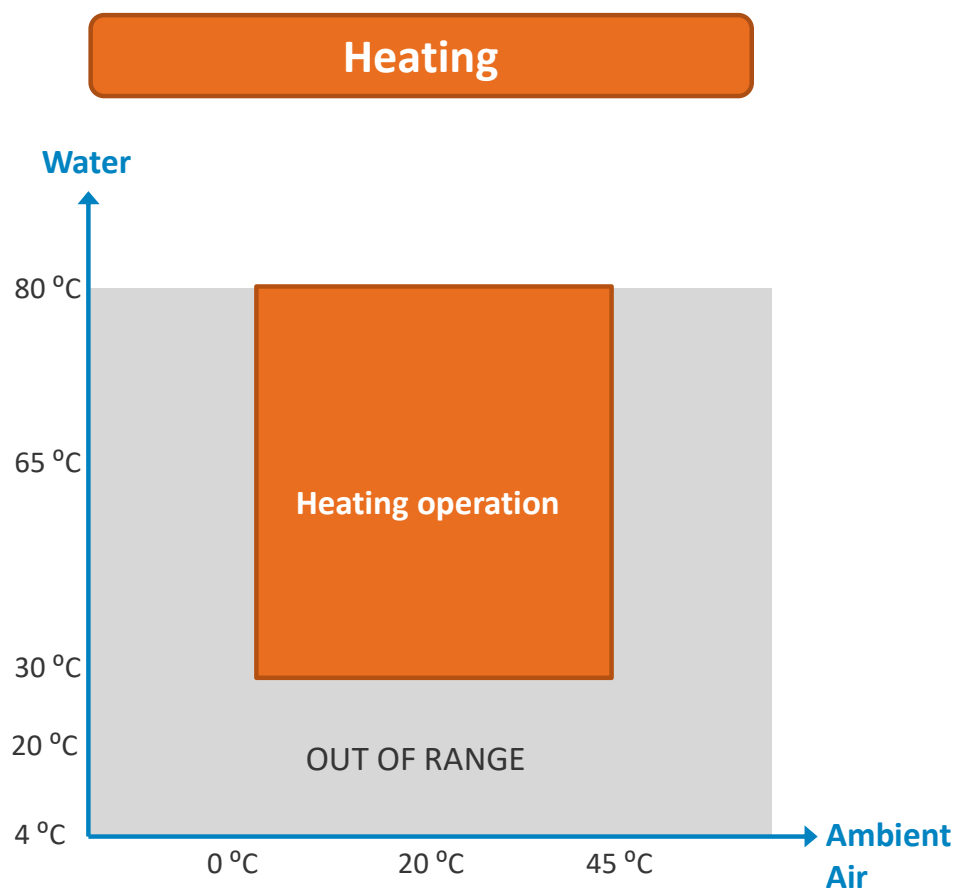

Note
(1) At 7/12°C regime
(2) At 45/40°C regime
(3) ISO7779 @1m

Specifications: Operation range



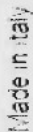

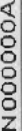
Specifications: Nameplate FWXV/FWXM

DAIKIN EUROPE N.V. , Zandvoordestraat 300, B-8400 Oostende, Belgium						
   	Type: HEAT PUMP CONVECTOR			COD: FWXV15AATV3		
	Power supply	230 V	Frequency	50 Hz	Matr. (S/N): 2105256	
	Power Input	25 W	Current cons.	0.22 A	Max pressure 10 bar / 1 MPa	
	Heating capacity	2860 W	Air flow	438 m³/h	Cooling cap. (tot.) 2640 W	

Brand name + address	DAIKIN EUROPE N.V. Zandvoordestraat 300, B-9000 Oostende Belgium					
Type (Description)	Heat pump convector					
COD (Product name)	FWXV10ABTV3	FWXV15ABTV3	FWXV20ABTV3	FWXM10AATV3	FWXM15AATV3	FWXM20AATV3
Voltage (V)	230	230	230	230	230	230
Frequency (Hz)	50	50	50	50	50	50
Power input (W)	19	25	31	19	20	29
Current constant (A)	0.17	0.22	0.27	0.17	0.17	0.25
Max pressure (bar/MPa)	10 / 1	10 / 1	10 / 1	10 / 1	10 / 1	10 / 1
Heating Capacity (W)	1960	2860	3500	2210	3020	3810
Airflow (m³/h)	294	438	567	294	438	567
Static Pressure (Pa)	10	13	13	10	13	13
Cooling Capacity (total) (W)	1620	2640	2990	2120	2810	3300
Matr. (S/N) (Serial number)	-	-	-	-	-	-
CE	CE	CE	CE	CE	CE	CE
IP protection	IPX0	IPX0	IPX0	IPX0	IPX0	IPX0
Country of origin	Italy	Italy	Italy	Italy	Italy	Italy

Specifications: Nameplate FWXT/FWXT-C

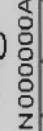
DAIKIN EUROPE N.V. , Zandvoordestraat 300, B-8400 Oostende, Belgium						
   	Type: HEAT PUMP CONVECTOR			COD: FWXT20AATV3C		
	Power supply	230 V	Frequency	50 Hz	Matr. (S/N): 2105565	
	Power Input	29 W	Current cons.	0,25 A	Max pressure 10 bar / 1 MPa	
	Heating capacity	2410 W	Air flow	440 m³/h	Cooling cap. (tot.) 1940 W	

Brand name + address	DAIKIN EUROPE N.V. Zandvoordestraat 300, B-9000 Oostende Belgium					
Type (Description)	Heat pump convector					
COD (Product name)	FWXT10ABTV3	FWXT15ABTV3	FWXT20ABTV3	FWXT10ABTV3C	FWXT15ABTV3C	FWXT20ABTV3C
Voltage (V)	230	230	230	230	230	230
Frequency (Hz)	50	50	50	50	50	50
Power input (W)	19	20	29	19	20	29
Current constant (A)	0.17	0.17	0.25	0.17	0.17	0.25
Max pressure (Bar/MPa)	10 / 1	10 / 1	10 / 1	10 / 1	10 / 1	10 / 1
Heating Capacity (W)	1500	2010	2410	1500	2010	2410
Airflow (m³/h)	228	331	440	228	331	440
Static Pressure (Pa)	10	10	10	10	10	10
Cooling Capacity (total) (W)	1240	1610	1940	1240	1610	1940
Mtr (S/N) (Serial number)	-	-	-	-	-	-
CE	CE	CE	CE	CE	CE	CE
IP protection	IPX0	IPX0	IPX0	IPX0	IPX0	IPX0
Country of origin	Italy	Italy	Italy	Italy	Italy	Italy

2.2. Details of speed setting for modulating mode

Speed modes for modulating controls (EKWHCTRL1(A), EKRTCTRL1, Remote Control)

Modulating speed allows the HPC to operate in the most optimal performance according to and considering:

- Users demand
- Sound level
- Energy

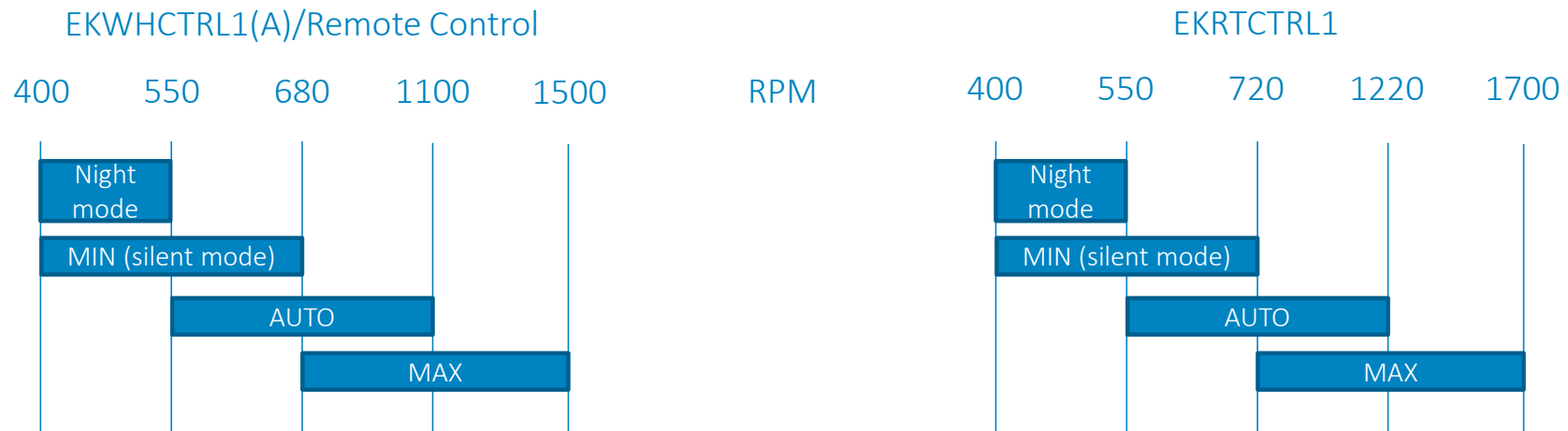

Background speed settings

register	name	description	range	step	default	unit	Readable/writable @Factory
210	MVV5	minimum motor fan speed in MIN and night mode	400 ... MVV3-4	1	400	rpm	R/W
211	MVV4	maximum motor fan speed in MIN and night mode	MVV5 ... MVV2	1	550	rpm	R/W
212	MVV3	maximum motor fan speed in MIN (silent mode) and minimum motor fan speed in MAX	MVV5 ... MVV1	1	680	rpm	R/W
230	MVVP3	maximum motor fan speed in MIN (silent mode) and minimum motor fan speed in MAX with performance enable	MVV5 ... MVV1	1	720	rpm	R/W
213	MVV2	maximum moter fan speed in AUTO	MVV4 ... 1500	1	1100	rpm	R/W
234	MVVP2	maximum motor fan speed in AUTO with performance enable	MVV4 ... 1500	1	1220	rpm	R/W
214	MVV1	maximum motor fan speed in MAX	MVV3 ... 1500	1	1500	rpm	R/W
215	MVVP1	maximum motor fan speed in MAX with performance enable	MVV1 ... 1700	1	1700	rpm	R/W

DIP switch ABCD
Disconnect HPC
from power
when changing
DIP switch

Control panel in normal mode with DIP switch A off (Default values)

MVV5 (400) MVV4 (550) MVV3 (680) MVV2 (1100) MVV1 (1500)

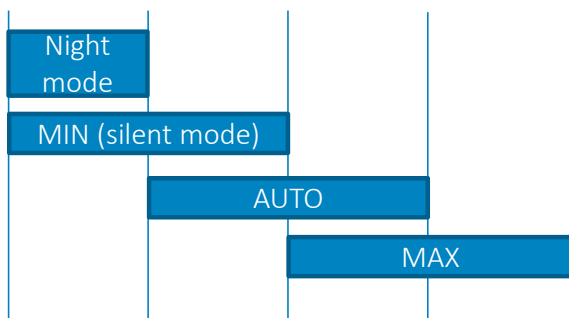

Control panel in performance mode with DIP switch A on (Default values)

MVV5 (400) MVV4 (550) MVVP3 (720) MVVP2 (1220) MVVP1 (1700)

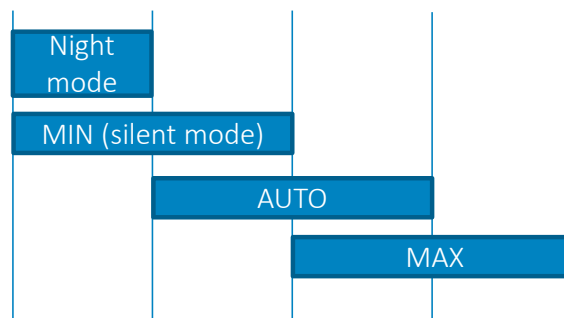

DAIKIN

2.3. Physical positions and options

Overview physical positions

FWXV

Vertical, floor standing

- Left (standard) or right (R) hand side hydraulic connection
- Piping through wall or through ceiling
- Optional aesthetic feet

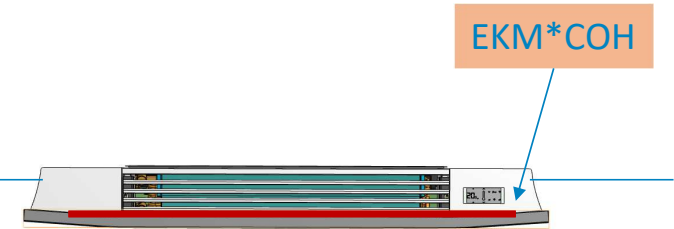
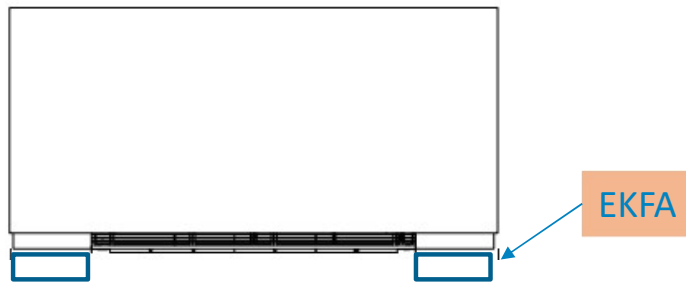

Horizontal, ceiling mounted

- Left (standard) or right (R) hand side hydraulic connection
- Piping through wall or through ceiling
- Condensate collector mandatory

Physical positions: options

FWXV

Position	Valve type	Piping direction	Connection side	Main unit	Feet	Valve kit	Additional hydraulic piece	Condensate collector
Vertical	2 way	From floor	Left / Right (R)	FWXV*A(B)TV3(R)	EKFA	EK2VK0	EKDIST	-
Vertical	2 way	From wall	Left / Right (R)	FWXV*A(B)TV3(R)	-	EK2VK0	EKEUR90	-
Vertical	3 way	From floor	Left / Right (R)	FWXV*A(B)TV3(R)	EKFA	EK3VK1	-	-
Vertical	3 way	From wall	Left / Right (R)	FWXV*A(B)TV3(R)	-	EK3VK1	EKDIST3W	-
Horizontal	2 way	From wall	Left / Right (R)	FWXV*A(B)TV3(R)	EKFA	EK2VK0	EKDIST	EKM*COH
Horizontal	2 way	From ceiling	Left / Right (R)	FWXV*A(B)TV3(R)	-	EK2VK0	EKEUR90	EKM*COH
Horizontal	3 way	From wall	Left / Right (R)	FWXV*A(B)TV3(R)	EKFA	EK3VK1	-	EKM*COH
Horizontal	3 way	From ceiling	Left / Right (R)	FWXV*A(B)TV3(R)	-	EK3VK1	EKDIST3W	EKM*COH

NEW

NEW

Overview physical positions

FWXM

Type A

- Vertical
- In wall
- Metal cover

EKM*CV

EKM*CS

Type B

- Horizontal
- In ceiling
- Intake metal cover
- Outlet grill
- Air in: vertical
- Air out: horizontal

EKM*DT

EKM*CS

EKM*SV

EKM*CH

Type C

- Horizontal
- In ceiling
- Intake/outlet grill
- Air in: vertical
- Air out: horizontal

EKM*SV

EKM*DT

EKM*DH

EKM*IS

Type D

- Horizontal
- In ceiling
- Intake/outlet grill
- Air in: vertical
- Air out: vertical

EKM*D90

EKM*CA

EKM*DH

EKM*IC

Physical positions: options

FWXM

Type	Piping type	Piping direction	Valve kit	Additional hydraulic piece	Casing	Cover	Intake grill	Airflow vent	Duct	Fitting	90° air bend
Type A	2 way	From floor	EK2VK0	EKDIST	EKM*CS	EKM*CV	-	-	-	-	-
Type A	2 way	From wall/side	EK2VK0	EKEUR90	EKM*CS	EKM*CV	-	-	-	-	-
Type A	3 way	From floor	EK3VK1	-	EKM*CS	EKM*CV	-	-	-	-	-
Type A	3 way	From wall/side	EK3VK1	EKDIST3W	EKM*CS	EKM*CV	-	-	-	-	-
Type B	2 way	From ceiling/side	EK2VK0	EKEUR90	EKM*CS	EKM*CH	-	EKM*SV	EKM*DT	-	-
Type B	2 way	From wall	EK2VK0	EKDIST	EKM*CS	EKM*CH	-	EKM*SV	EKM*DT	-	-
Type B	3 way	From ceiling/side	EK3VK1	EKDIST3W	EKM*CS	EKM*CH	-	EKM*SV	EKM*DT	-	-
Type B	3 way	From wall	EK3VK1	-	EKM*CS	EKM*CH	-	EKM*SV	EKM*DT	-	-
Type C	2 way	From ceiling/side	EK2VK0	EKEUR90	-	-	EKM*IS	EKM*SV	EKM*DT	EKM*DH	-
Type C	2 way	From wall	EK2VK0	EKDIST	-	-	EKM*IS	EKM*SV	EKM*DT	EKM*DH	-
Type C	3 way	From ceiling/side	EK3VK1	EKDIST3W	-	-	EKM*IS	EKM*SV	EKM*DT	EKM*DH	-
Type C	3 way	From wall	EK3VK1	-	-	-	EKM*IS	EKM*SV	EKM*DT	EKM*DH	-
Type D	2 way	From ceiling/side	EK2VK0	EKEUR90	-	-	EKM*IC	EKM*CA	-	EKM*DH	EKM*D90
Type D	2 way	From wall	EK2VK0	EKDIST	-	-	EKM*IC	EKM*CA	-	EKM*DH	EKM*D90
Type D	3 way	From ceiling/side	EK3VK1	EKDIST3W	-	-	EKM*IC	EKM*CA	-	EKM*DH	EKM*D90
Type D	3 way	From wall	EK3VK1	-	-	-	EKM*IC	EKM*CA	-	EKM*DH	EKM*D90

NEW

NEW

NEW

NEW

Overview physical positions

FWXT/FWXT-C

Vertical, high wall

- Right (standard) or left (R) hand side hydraulic connection
- Piping through wall

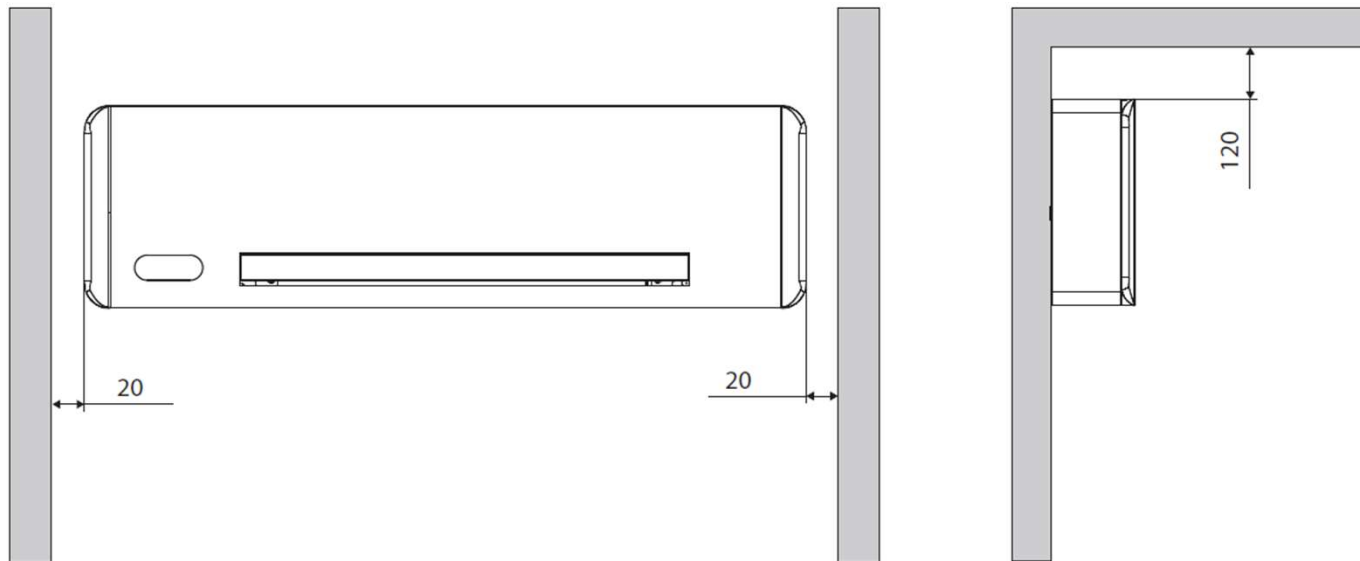

Physical positions: options





FWXT/FWXT-C

Position	Piping type	Connection side	Main unit	Valve kit	Condensate collector
Vertical	2 way	Right / Left	FWXT*	EKT2VK0	-
Vertical	3 way	Right / Left	FWXT*	EKT3VK1	-

Options: Overview (1/3)

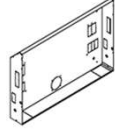
Material	Description	Image
EKFA	Aesthetical feet	
EK2VK0	Motorized 2-way valve (FWXV/M) – flexible by-pass hose	
EK3VK1	Motorized 3-way valve (FWXV/M) – flexible by-pass hose	
EKT2VK0	Motorized 2-way valve (FWXT) – copper by-pass pipe	
EKT3VK1	Motorized 3-way valve (FWXT) – copper by-pass pipe	
EKEUR90	L-bow 90°	
EKDIST	Extension piece	

Options: Overview (2/3)

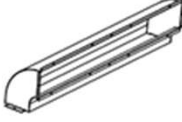
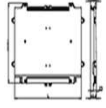
	Material		Description	Image
	Size 10	Size 15		
EKM10CS	EKM15CS	EKM20CS	Metal casing	
EKM10CH	EKM15CH	EKM20CH	Front cover for ceiling installation	
EKM10CV	EKM15CV	EKM20CV	Front cover for wall installation	
EKM10DH	EKM15DH	EKM20DH	Air intake fitting	
EKM10D90	EKM15D90	EKM20D90	90° exhaust bend	
EKM10COH	EKM15COH	EKM20COH	Condensate collector tray <ul style="list-style-type: none"> • Option on FWXV for horizontal mounting • Standard on FWXM 	

Options: Overview (3/3)

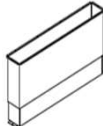
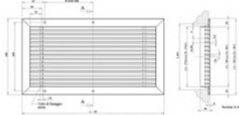
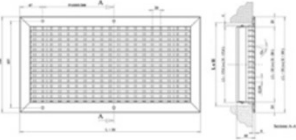
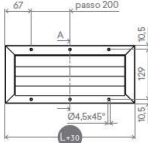
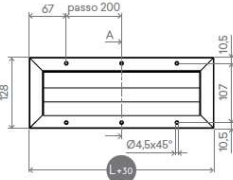
Material			Description	Image
Size 10	Size 15	Size 20		
EKM10DT	EKM15DT	EKM20DT	Telescopic air flow duct	
EKM10IS	EKM15IS	EKM20IS	Aluminum air intake grill with straight airflow	
EKM10SV	EKM15SV	EKM20SV	Straight airflow vent	
EKM10IC	EKM15IC	EKM20IC	Aluminum air intake grill with curved airflow	
EKM10CA	EKM15CA	EKM20CA	Aluminum air outlet grill with curved airflow	

Options: EKFA

Material	Description	Image
EKFA	Aesthetical feet RAL9010	



*Not to be used as support for the unit.
Only aesthetical view!*

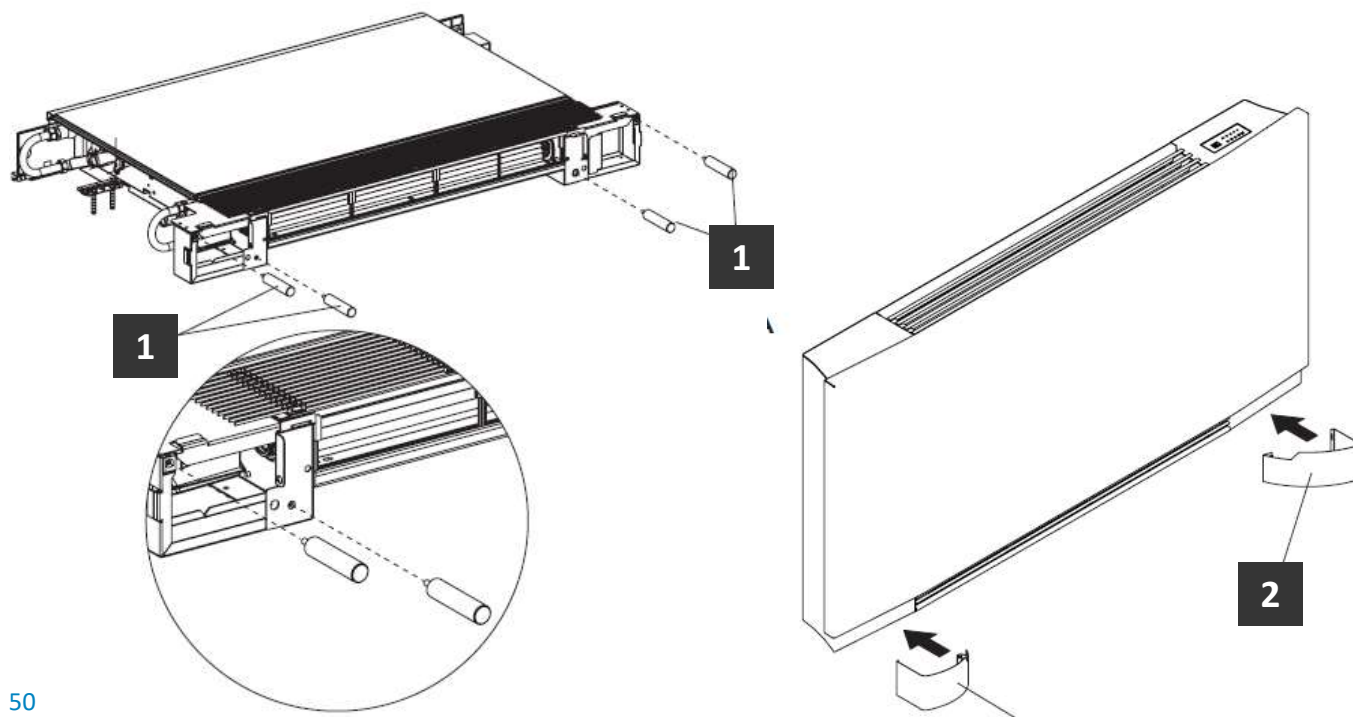

N°	Description
1	Threaded supports
2	Supports cover

Options: EK2VK0

Material	Description	Image
EK2VK0	Motorized 2-way valve (FWXV/M)	

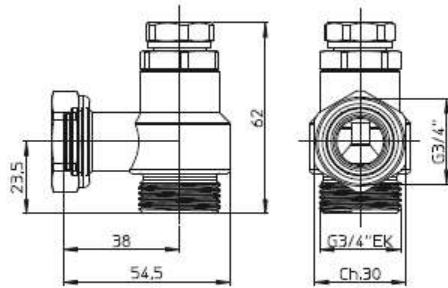
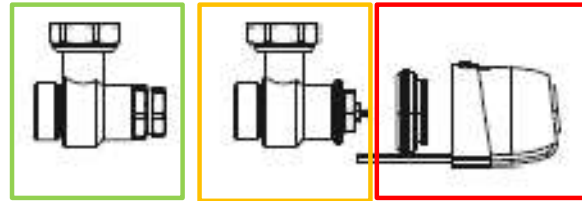

Hydraulic lockshield

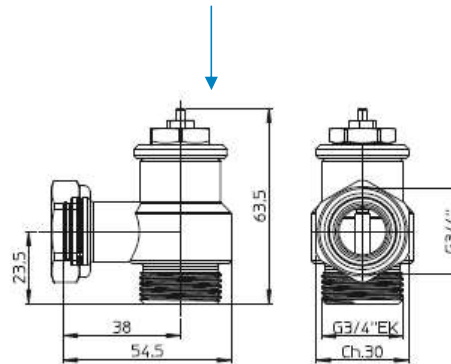

Closure valve

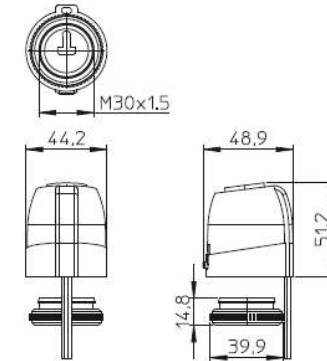

Electrothermal motor

Options: EKT2VK0

Material	Description	Image
EKT2VK0	Motorized 2-way valve (FWXT)	

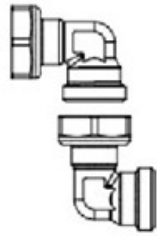

2x Elbow

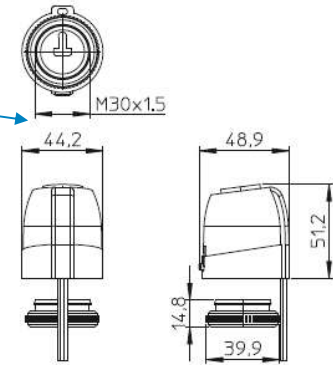
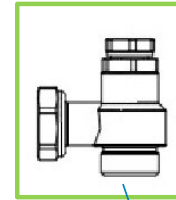
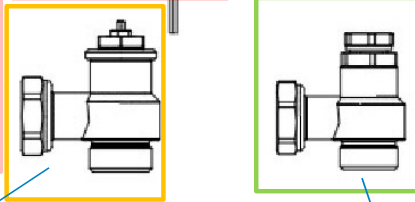
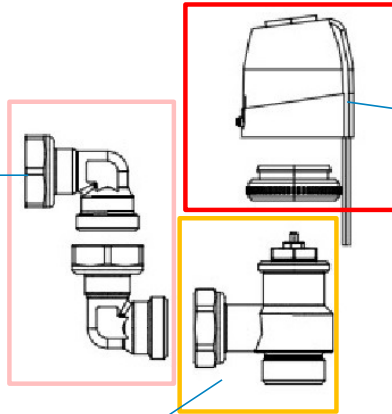

Electrothermal motor

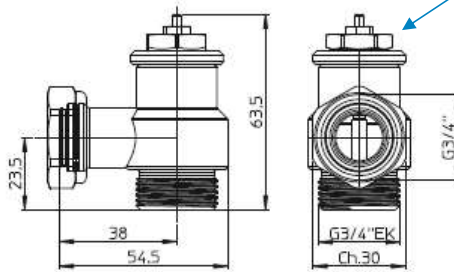

Closure valve

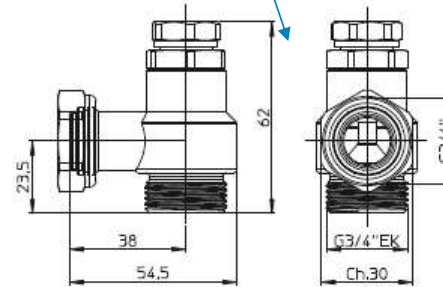

Hydraulic lockshield

Options: EK3VK1

Material	Description	Image
EK3VK1	Motorized 3-way valve (FWXV/M)	

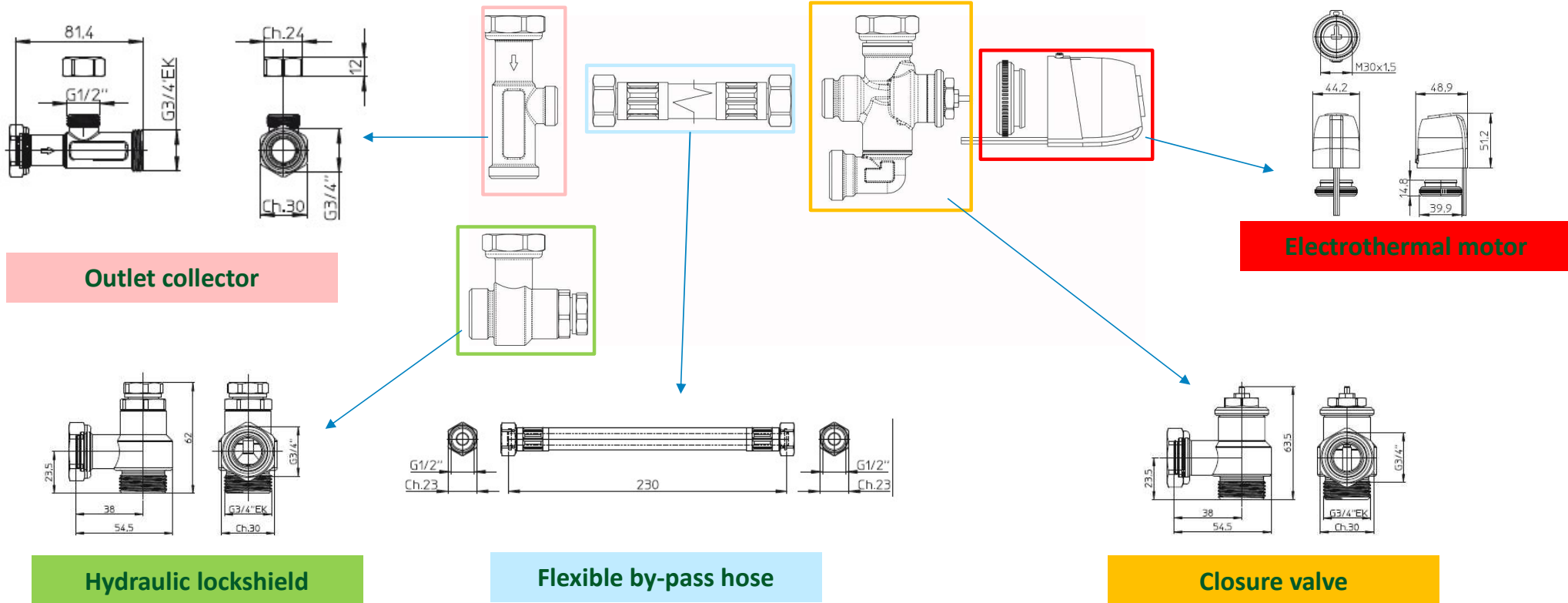

Options: EKT3VK1

Material	Description	Image
EKT3VK1	Motorized 3-way valve (FWXT)	

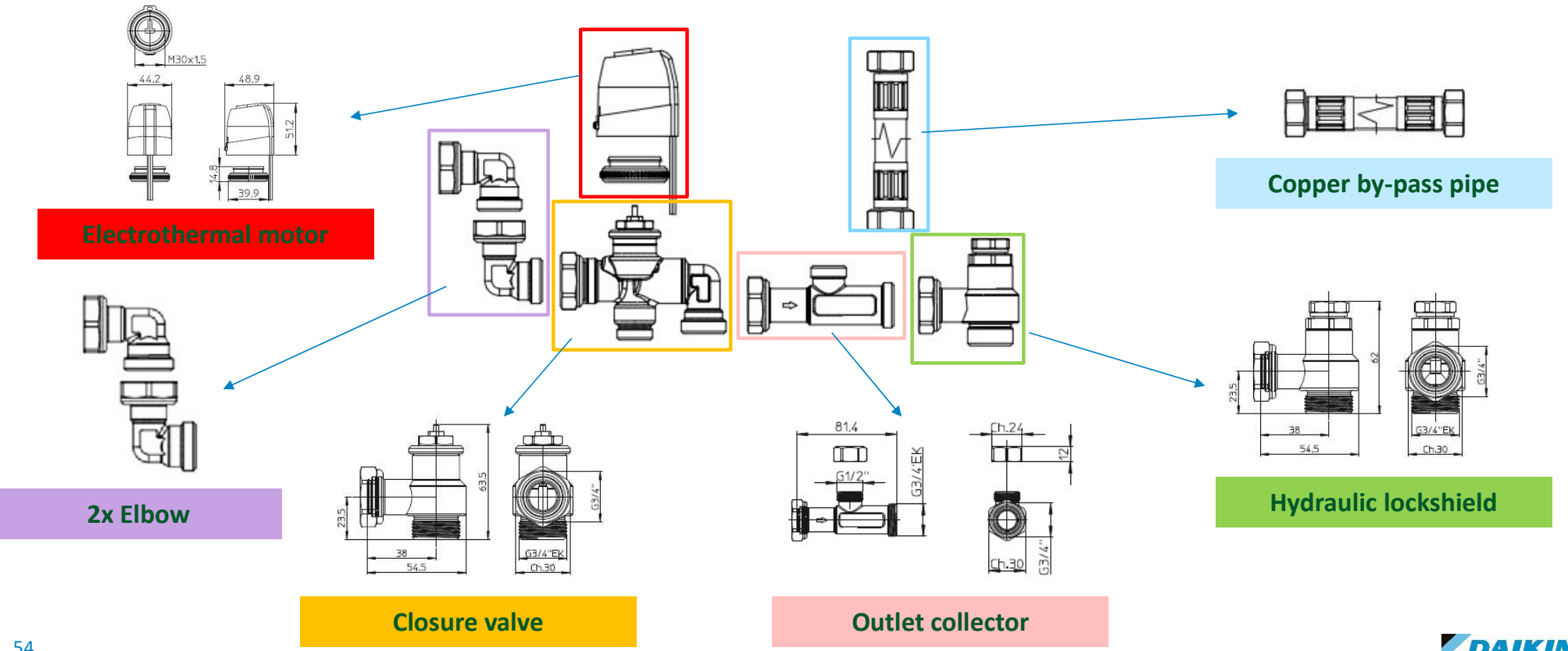

Options: EKDIST

Material	Description	Image
EKDIST	Extension piece	

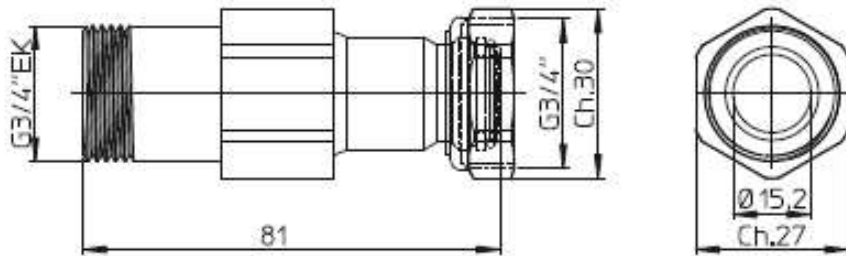

1 Extension piece

Spacer for closure valve. For easier connection to the valve body on piping that is difficult to bend. Enables the valve to be moved outwards, considerably reducing the need to bend piping coming through the floor or low on a wall.

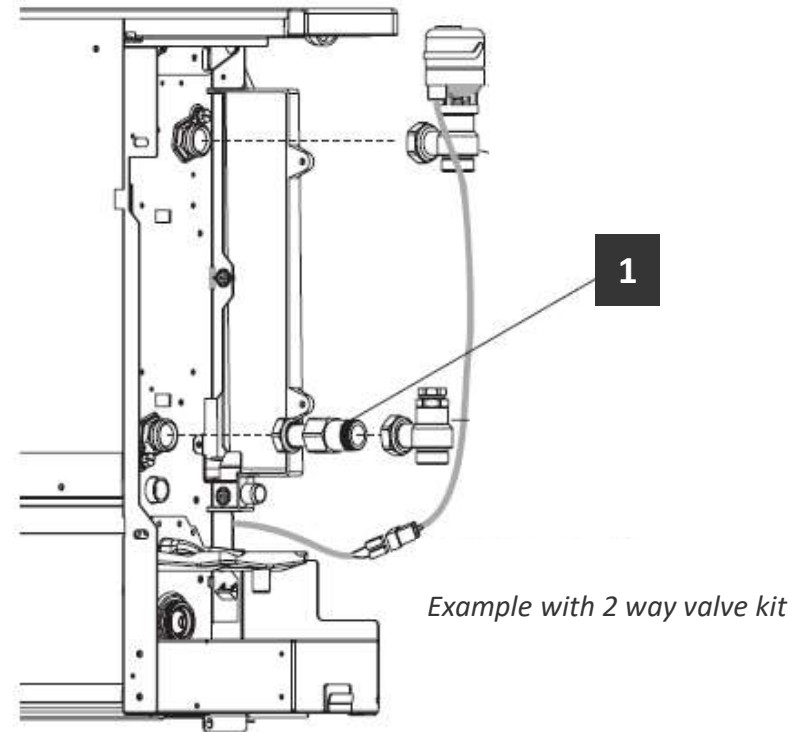

Options: EKEUR90

Material	Description	Image
EKEUR90	L-bow 90°	

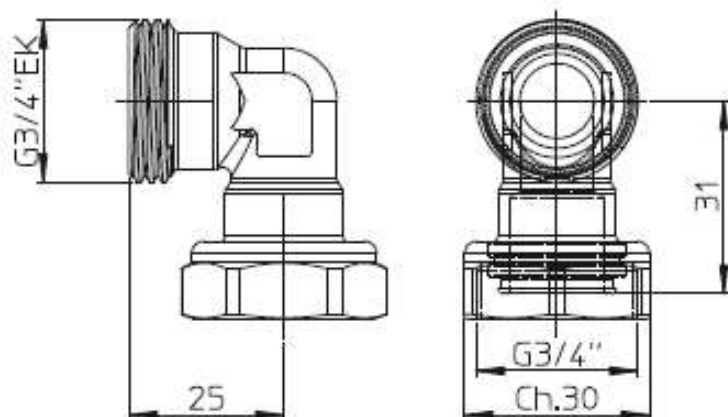

1 L-Bow 90°

90° fitting with EUROKONUS connection. For easy connection of piping with axis turned 90° away from valves axis

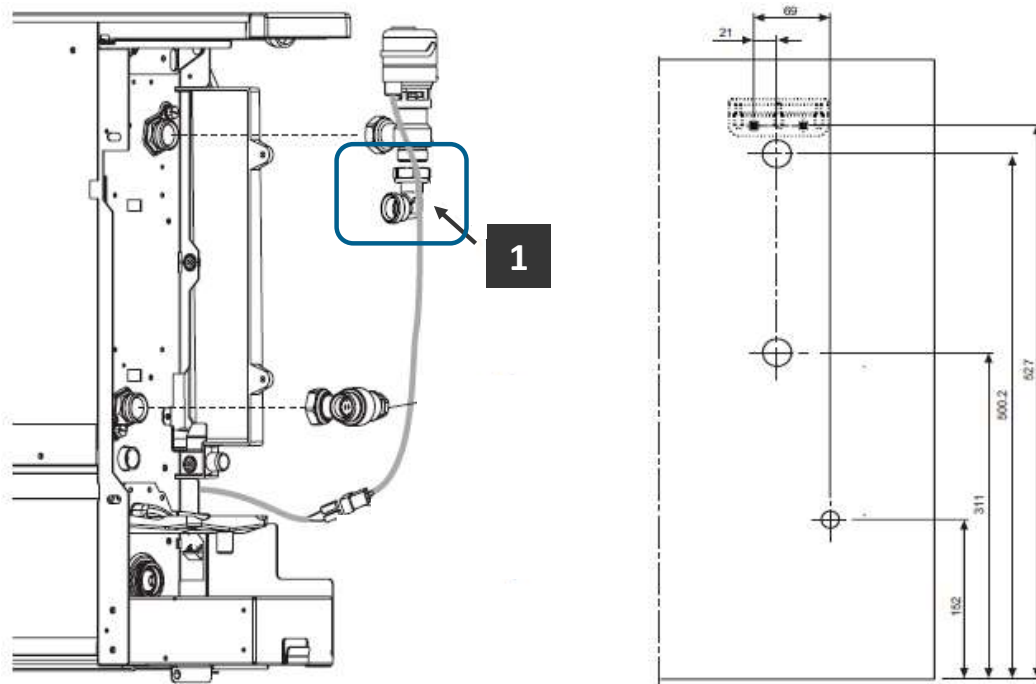

Options: Condensate collector tray - FWXV

Material	Description	L
EKM10COH	The accessory consists of an ABS tray that is easily assembled to the front of the terminal below the outer casing. The tray comes with the relative insulating material and all the fittings required for condensate drain installation.	681
EKM15COH		881
EKM20COH		1081

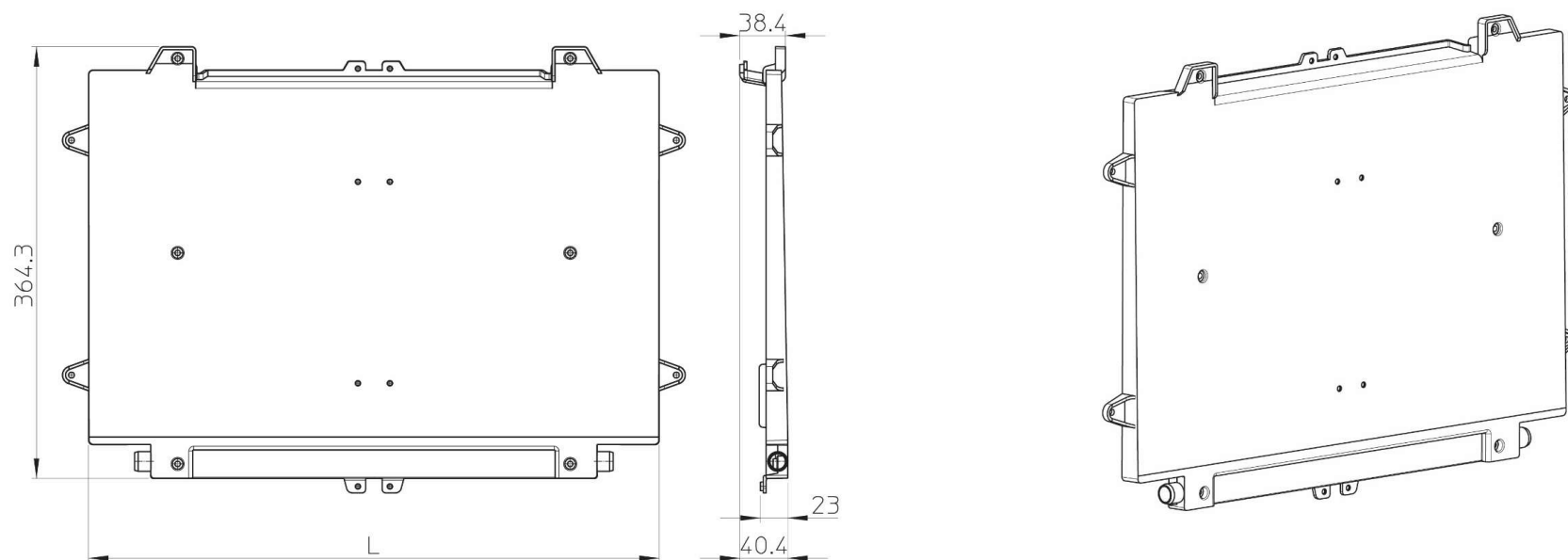

Options: Metal casing - FWXM

Material	Description	L
EKM10-15-20CS	This accessory is a galvanized sheet metal casing made to be inserted into the wall or false ceiling where the terminal is housed. It is pre-cut to allow for routing of hydraulic pipes and electric cables. The structure fits to the built-in cover panel described below. This accessory enables the inner workings of our terminals to run simply and accurately. Its slimness (due to the compactness of our terminals) enables it to be positioned in very thin walls and false ceilings.	915
EKM10-15-20CS		1115
EKM10-15-20CS		1315

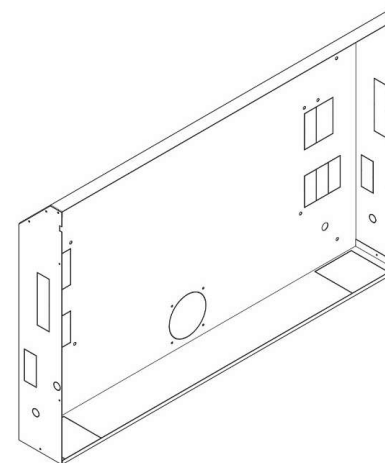
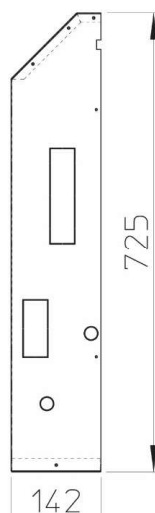
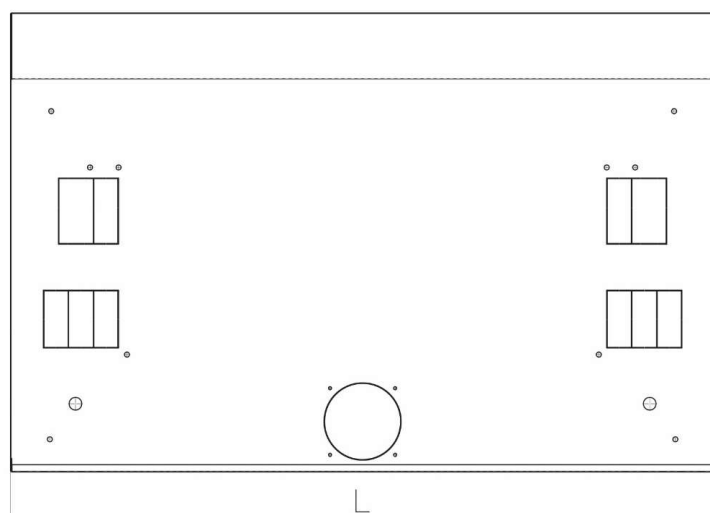

Options: Front cover for ceiling/wall installation - FWXM

Material	Description	L
EKM10CH/V	The panel is designed to fit perfectly to the built-in casing of the same size. It includes: outer frame, front panel, removable grill for cleaning air filters and adjustable deflector for diverting ambient air flow (only for vertical model).	972
EKM15CH/V		1172
EKM20CH/V	The middle of the panel can be easily removed for rapid and thorough maintenance of the appliance. Its quality finish means it will blend perfectly into any setting. The standard color is RAL 9010 white but different colors are available on request.	1372

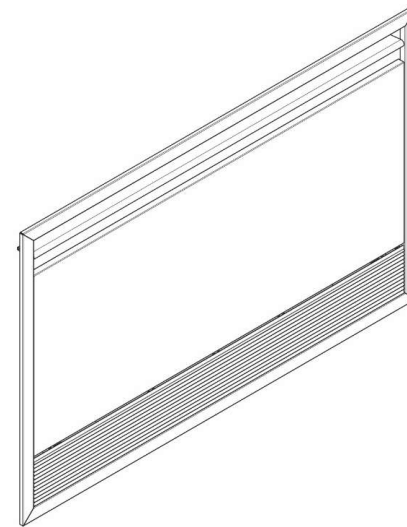
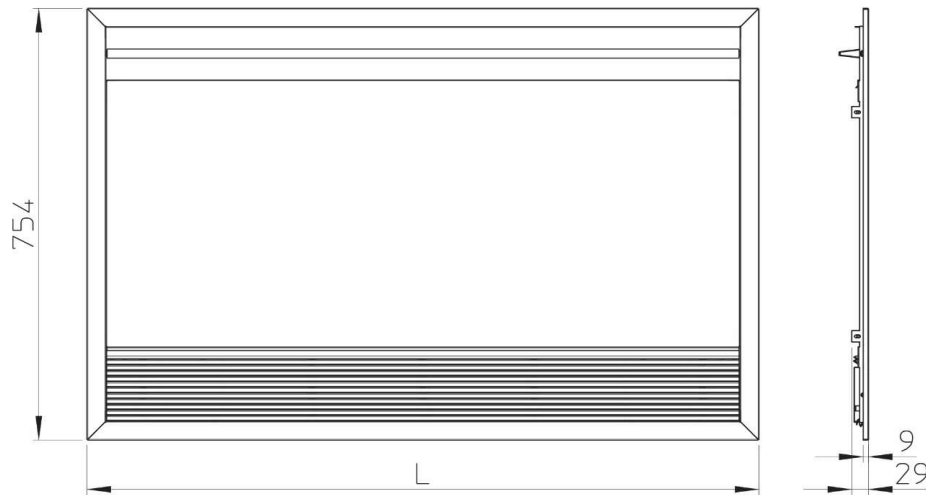

Options: Telescopic air flow duct - FWXM

Material	Description	L
EKM10DT	This accessory facilitates the application of our built-in terminals inside false ceilings.	507,5
EKM15DT	There are many situations in which the terminal cannot be connected directly to the air vent (e.g. in hotel rooms). Our telescopic duct is adjustable in length to better adapt to installation requirements.	707,5
EKM20DT	It is made of galvanized sheet metal coated on the inside with insulating material to prevent condensation.	907,5

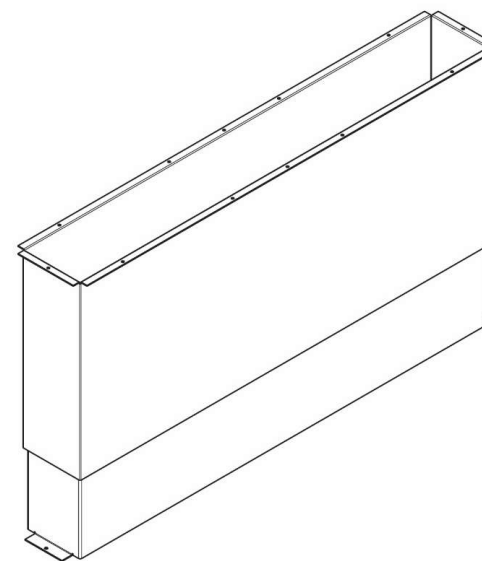
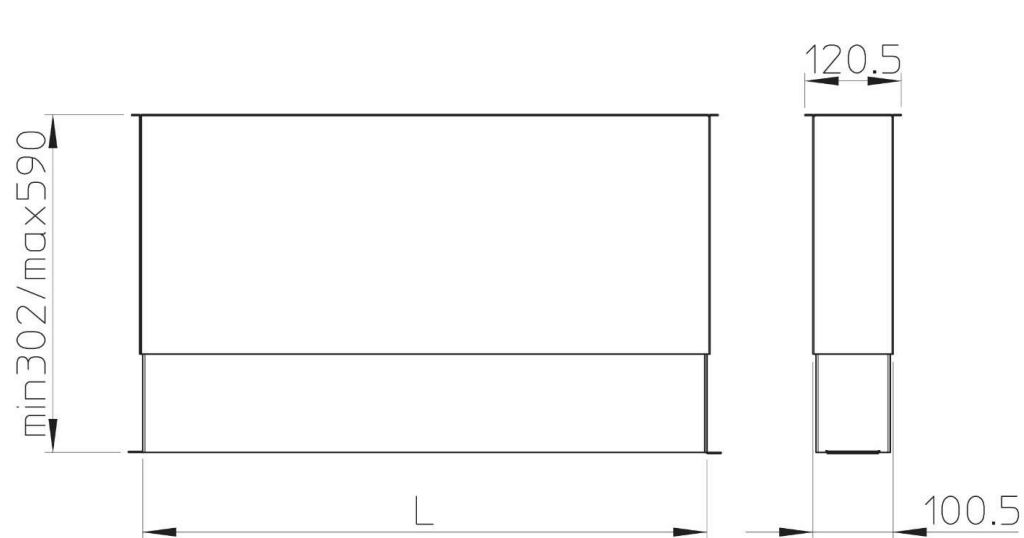

Options: Straight airflow vent - FWXM

Material	Description	H x L
EKM10SV	The accessory comprises an aluminum vent with two rows of fins for horizontal and vertical adjustment of the air flow. It is ideal for built-in terminals in which the air flow is directed into the room from a wall or from the vertical side of a false ceiling (as in hotel rooms). The dimensions and holes on the frame fit perfectly to the accessories: telescopic duct and 90° duct.	98 x 504
EKM15SV		98 x 704
EKM20SV		98 x 904

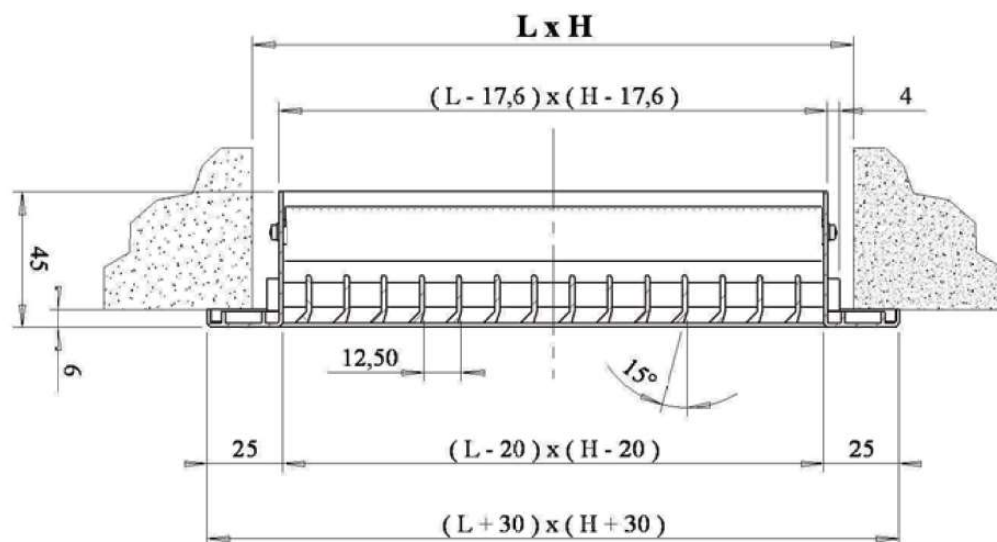
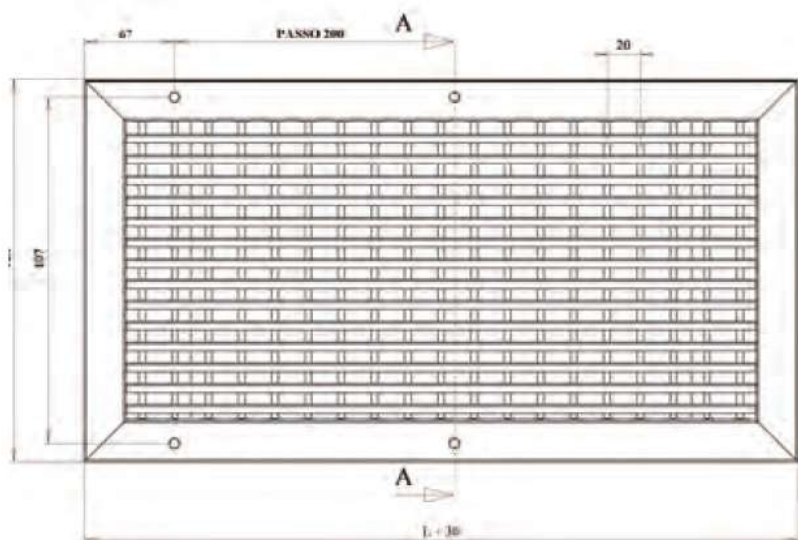

Options: Aluminum air intake grill - FWXM

Material	Description	H x L
EKM10IS	An aluminum intake grill with a linear profile that fits perfectly to our air intake fittings for the built-in installation described above. The aluminum frame	120 x 504
EKM15IS	surrounding the grill has a series of holes for fastening to the intake fitting.	120 x 704
EKM20IS	This element guarantees easy removal of the grill for periodic cleaning of the air filters.	120 x 904

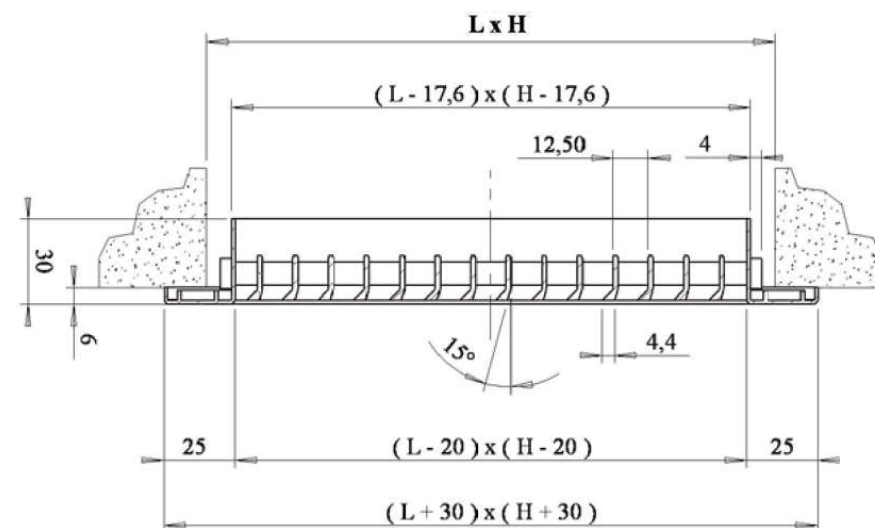
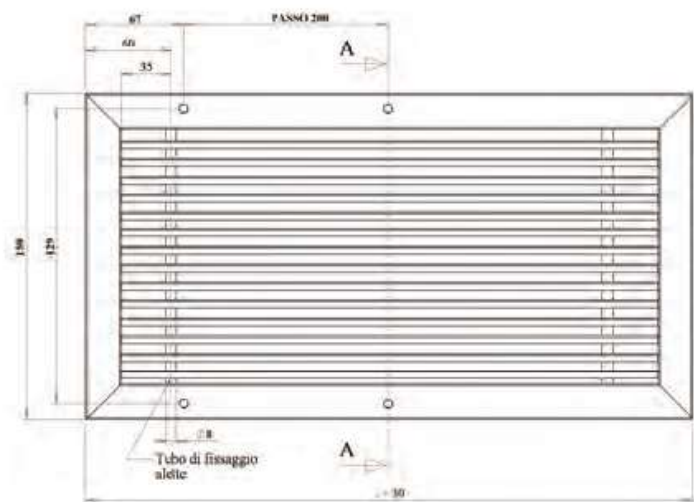

Options: Air intake fitting - FWXM

Material	Description	L
EKM10DH	This fitting is used to conduct ambient air from a return grill on a false ceiling or wall to the terminal installed horizontally inside the false ceiling or vertically inside a wall. The dimensions and configuration of this accessory, made of galvanized sheet metal, enable perfect accessibility to the air filters.	505
EKM15DH		705
EKM20DH		905

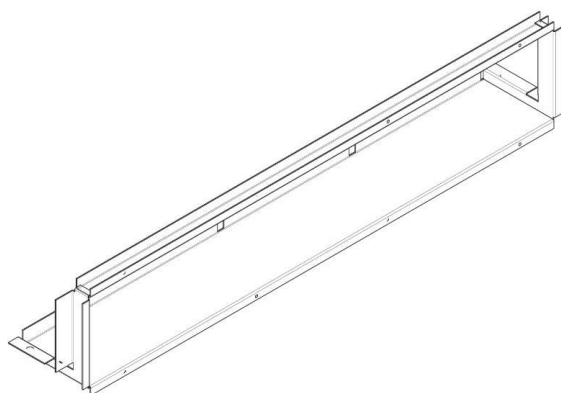
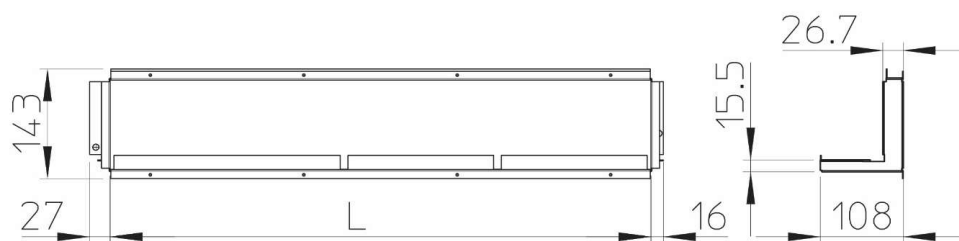

Options: 90° exhaust bend - FWXM

Material	Description	L
EKM10D90	This accessory enables air flow from the built-in terminal to be ducted towards a vent set at right angles to the air outlet. A common application is for terminals installed horizontally inside a false ceiling with the relative vent on the visible lower surface of the false ceiling. It is made of galvanized sheet metal coated on the inside with insulating material.	507,5
EKM15D90		707,5
EKM20D90		907,5

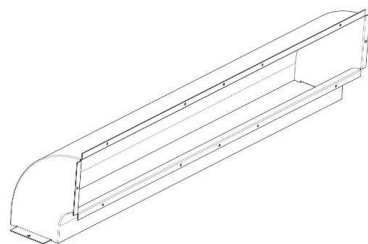
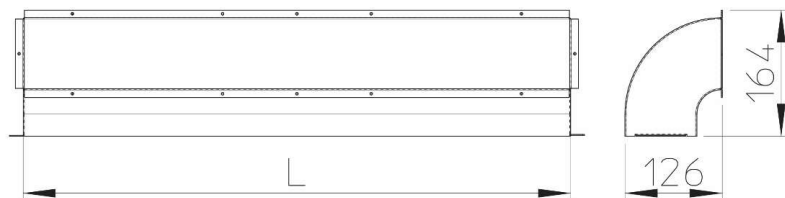

Options: Aluminum air outlet grill with curved airflow

Material	Description	L
EKM10CA	The aluminum curved vent is particularly suited for air distribution from a false ceiling. The geometry of the individual fins enables mainly horizontal air flow which does not disturb the people inside the room. Its elegant appearance blends well with any setting. It fits perfectly to both the 90° duct and the telescopic duct.	504
EKM15CA		704
EKM20CA		904

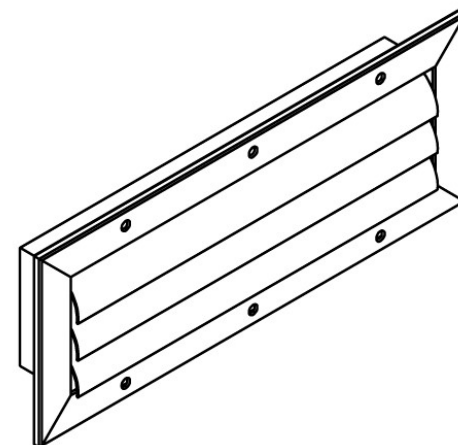
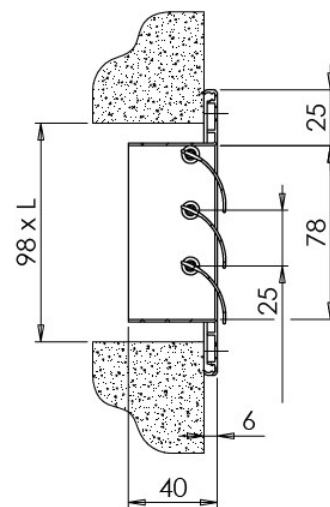
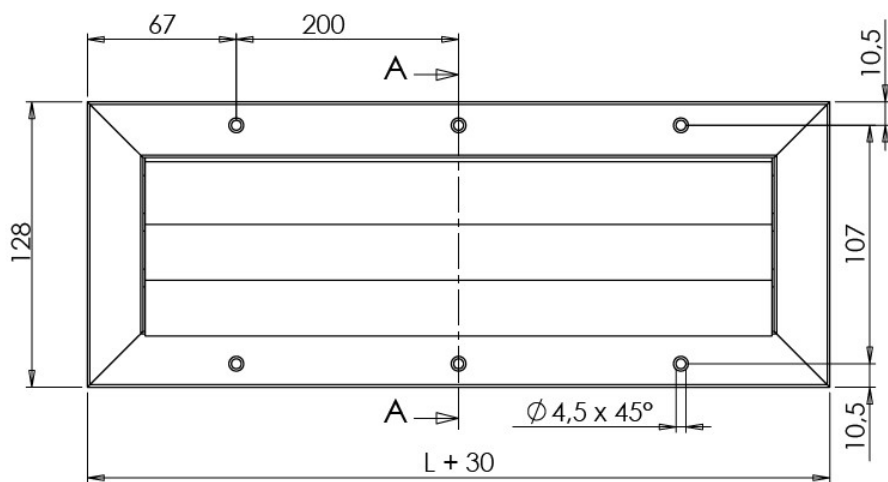

Options: Aluminum air intake grill with curved airflow - FWXM

Material	Description	L
EKM10IC	This type of aluminum air intake grill is particularly suited for false ceiling installations. Its curved profile completely conceals the interior, giving a more elegant appearance.	504
EKM15IC		704
EKM20IC	Just like the other grills, this one also fits perfectly to the dimensions and holes on our air intake fitting for built-in terminals.	904

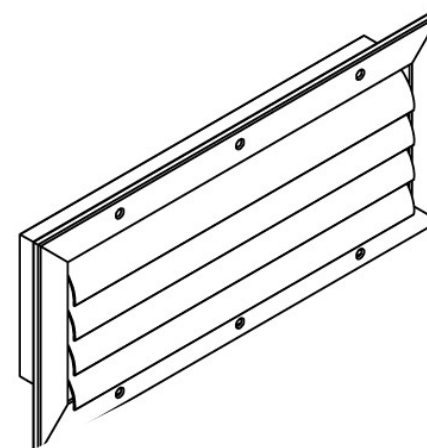
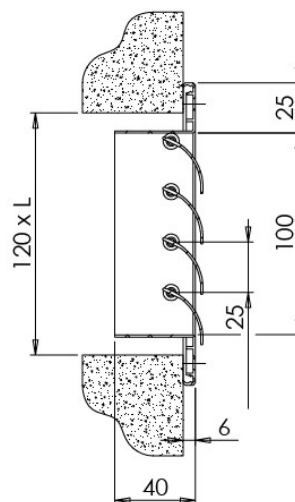
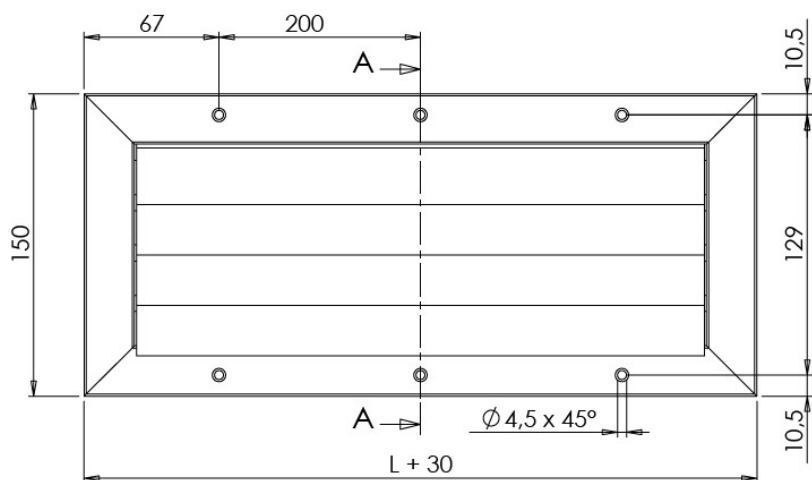







2.4. Controls and control options

Controls: Overview

Picture	Name	Type	other material mandatory required?	Location	Type of speed control	HPC model			
						FWXV	FWXM	FWXT	FWXT-C
	EKRCTRL1	control interface	no	on unit	modulating speed	V			
	EKRTCTRL2	control interface	no	on unit	4 step speed	V			
	EKWHCTRL1	control interface	FWXV/FWXM: EKWHCTRL0 FWXT: no	on wall	modulating speed	V	V	V	
	EKWHCTRL1A	control interface	EKWHCTRL0 + EKFC80	on wall	modulating speed	V			
	EKWHCTRL0	PCB	EKWHCTRL1 // EKWHCTRL2	in unit	modulating speed	V	V		
	EKPCBO	PCB + control interface	3rd party on/off thermostat	in unit	on/off	V			
	EKPCB4S	PCB	3rd party 3 or 4 speed thermostat	in unit	4 step speed	V	V		
	EKPCB10	PCB	3rd party 1-10V thermostat	in unit	1-10V speed	V	V		
	IR remote control	control interface	no	remote control	modulating speed				V

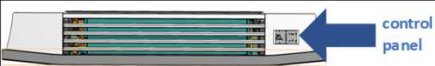
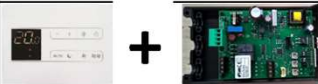
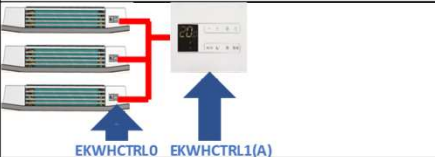

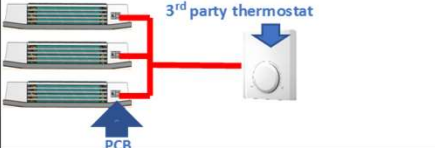
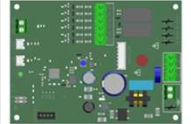
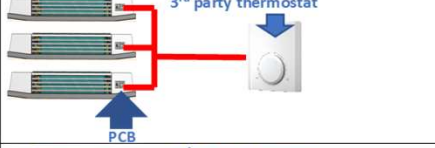

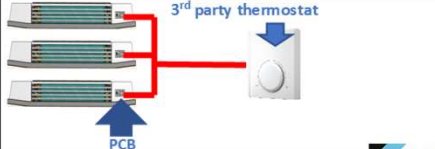
Controls: Ordering - FWXV

The HPC unit comes without controller. One of the following controller options needs to be ordered and installed.

option	picture	material	description	amount	connection
1		EKTRCTRL1	On board electronic control SMART TOUCH with PID full modulating fan and thermostat	1/HPC	
2		EKRTCTRL2	On board electronic control SMART TOUCH 4 speeds with thermostat	1/HPC	
3		EKWHCTRL1 + EKWHCTRL0 EKWHCTRL1A + EKWHCTRL0 + EKFC80	SMART LCD wall controller with temperature probe, white casing; connecting up to 30 HPC units	EKWHCTRL1(A): 1/climate zone (*) EKWHCTRL0: 1/HPC	
4		EKPCBO	On board PCB for on/off control of HPC	3rd party on/off thermostat: 1/climate zone (*) B3V137: 1/HPC	
5		EKPCB4S	On board PCB for 3 speed control of HPC	3rd party 3 speed thermostat: 1/climate zone (*) B3V137: 1/HPC	
6		EKPCB10	On board PCB for 1-10V speed control of HPC	3rd party 1-10V thermostat: 1/climate zone (*) B3V137: 1/HPC	

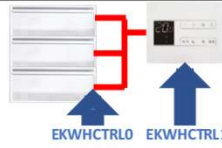
Controls: Ordering - FWXM

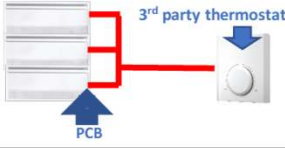
The HPC unit comes without controller. One of the following controller options needs to be ordered and installed.

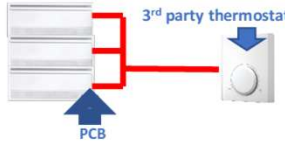
option	picture	material	description	amount	connection
1		EKWHCTRL1 + EKWHCTRL0	SMART LCD wall controller with temperature probe, white casing; connecting up to 30 HPC units	EKWHCTRL1: 1/climate zone (*) EKWHCTRL0: 1/HPC	
2		EKPCB4S	On board PCB for 4 speed control of HPC	3rd party 4 speed thermostat: 1/climate zone (*) EKPCB4S: 1/HPC	
3		EKPCB10	On board PCB for 1-10V speed control of HPC	3rd party 1-10V thermostat: 1/climate zone (*) EKPCB10: 1/HPC	

Controls: Ordering - FWXT

The HPC unit comes with on-board controller. But an extra climate zone controller can be ordered.

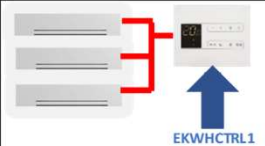
option	picture	material	description	amount	connection
1		EKWHCTRL1	SMART LCD wall controller with temperature probe, white casing; connecting up to 30 HPC units	1/climate zone (*)	







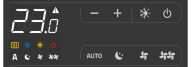

Controls: Ordering – FWXT-C

The HPC unit comes with remote controller. **NO** extra option can be ordered.

No connection with EKWHCTRL1(A) possible, no MODbus connection possible.



Controls – overview options:

Material	Description	Image
EKRTCTRL1	On board electronic control SMART TOUCH with PID full modulating fan and thermostat	
EKRTCTRL2	On board electronic control SMART TOUCH 4 speeds with thermostat	
EKWHCTRL1	SMART LCD wall controller with temperature probe, white casing	
EKWHCTRL1A	SMART LCD wall controller with temperature probe and IAQ sensor, white casing, in combination with EKFC80	
EKWHCTRL0	On board PCB for EKWHCTRL1	
EKPCBO	On board touch panel (incl. PCB) for on/off control to be combine with 3 rd party on/off thermostats	
EKPCB4S	On board PCB for 4 speed control to be combine with 3 rd party 3 or 4 speed thermostats	
EKPCB10	On board PCB for 1-10V speed control to be combine with 3 rd party 10V thermostats	
EKFC80	Damper kit for FWXV always in combination with controller EKWHCTRL1A	

Controls – overview options: EKRTCTRL1

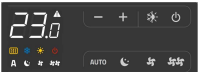
Material	Description	Image
EKRTCTRL1	On board electronic control SMART TOUCH with PID full modulating fan and thermostat	

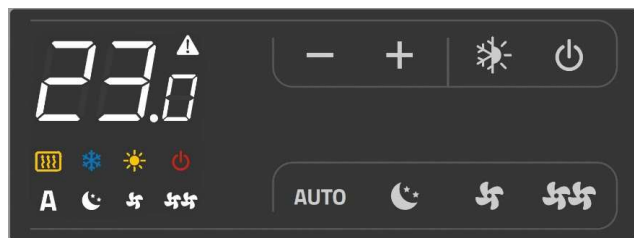

A	Automatic operation
	Silent operation
	Maximum ventilation speed
	Night-time operation
	Heating on
	Cooling on
	Supervision on Flashing with presence switch CP closed.
	Alarm indicator (solid light)
	Panel off indicator

Key functions

+	Temp + is for increasing the set temperature
-	Temp - is for decreasing the set temperature
	Heating / Cooling: for changing the operation mode between heating and cooling
AUTO	Sets the regulation ventilation speed between a minimum and maximum value to an entirely automatic mode
	Night-time operation: limits ventilation speed to a contained level and the set temperature is adjusted automatically.
	Maximum speed operation: Allows for the maximum ventilation speed to be set
	ON/Stand-By: for activating the device or for putting it in stand-by.
	Silent: limits ventilation speed to a more contained value

- ✓ Easy to configure
- ✓ Operating in modulating principle
- ✓ Heating and cooling mode

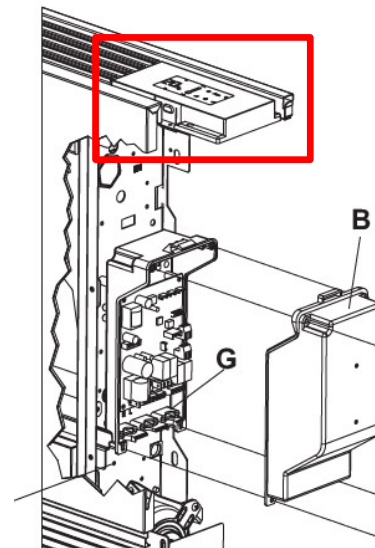

Controls – overview options: EKRTCTRL1 - Wiring diagram

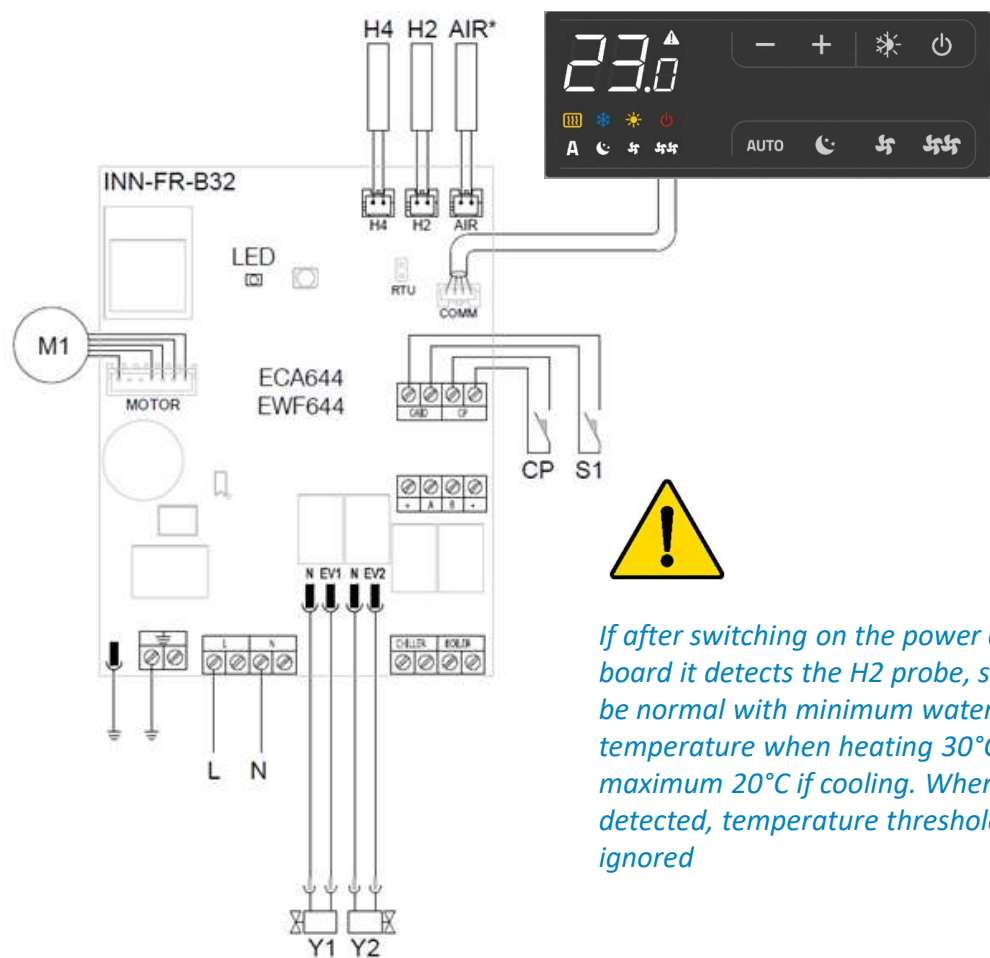

If after switching on the power of the board it detects the H2 probe, start up will be normal with minimum water temperature when heating 30°C and maximum 20°C if cooling. When no H2 is detected, temperature thresholds will be ignored

Part	Description
+AB-	ModBus RTU serial connection
H2	Hot water temperature probe 10kΩ
AIR	Air temperature probe 10kΩ
M1	DC inverter fan motor
S1	Grill safety micro switch => standard closed
CP	Presence input sensor (NO contact) => standard open
Y1	Water solenoid valve 230V/50Hz 1A output
Y2	Mobile flap connection 230V/50Hz 1A output voltage
L-N	230V/50Hz power supply
BO	Boiler consent output (free contact max 1A)
CH	Chiller consent output (free contact max 1A)

Controls – overview options: EKRTCTRL2

Material	Description	Image
EKRTCTRL2	On board electronic control SMART TOUCH 4 speeds with thermostat	

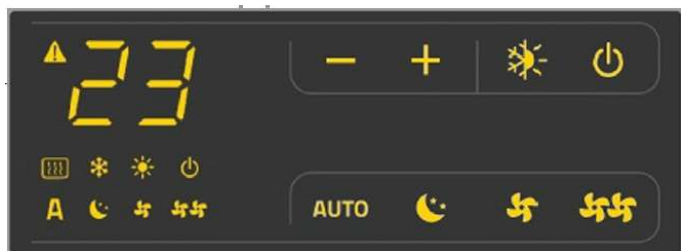

A	Automatic operation in steps
	Minimum operation
	Maximum ventilation speed
	Super silent operation
	Heating on
	Cooling on
	Supervision active (flashing light)
	Alarm indicator (solid light)
	Panel off indicator

Key functions

+	Temp + is for increasing the set temperature by 1 K
-	Temp - is for decreasing the set temperature by 1 K
	Heating / Cooling: for changing the operation mode between heating and cooling
AUTO	In automatic mode, the fan carries out a "stepped" adjustment to move the room temperature closer to the set point.
	The super silent setting activates powerful dehumidifying when cooling and only radiation when heating.
	Maximum speed operation: Allows for the maximum ventilation speed to be set
	ON/Stand-By: for activating the device or for putting it in stand-by.
	Minimum: limits ventilation speed to a very contained value

- ✓ Easy to configure
- ✓ Operating in 4 step principle
- ✓ Heating and cooling mode

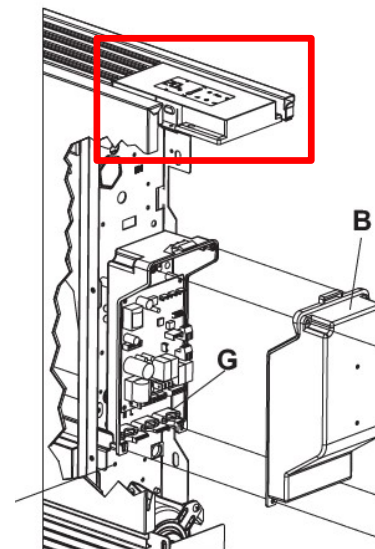

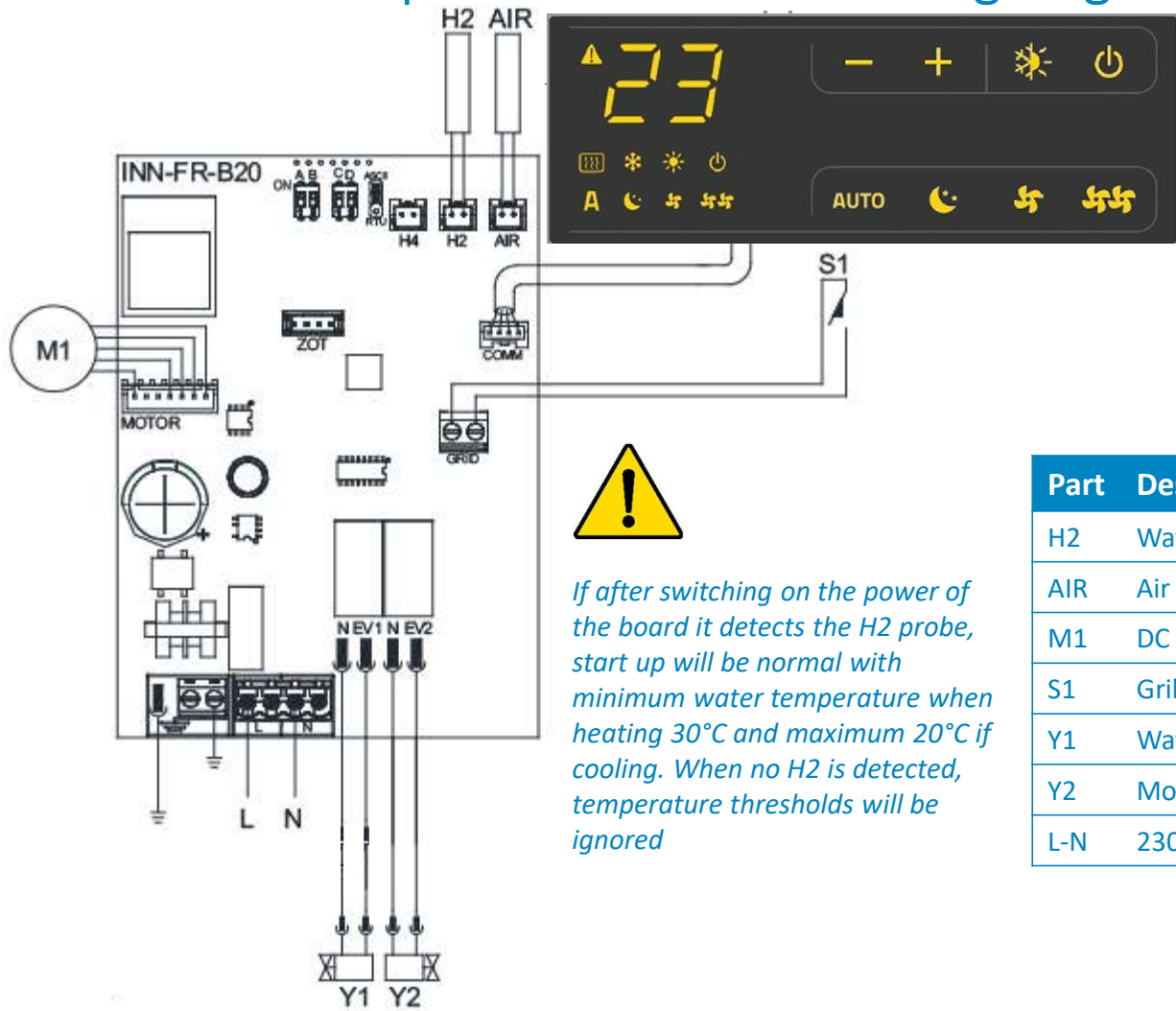

Controls – overview options: EKRTCTRL2 Wiring diagram



If after switching on the power of the board it detects the H2 probe, start up will be normal with minimum water temperature when heating 30°C and maximum 20°C if cooling. When no H2 is detected, temperature thresholds will be ignored

Part	Description
H2	Water temperature probe 10kΩ
AIR	Air temperature probe 10kΩ
M1	DC inverter fan motor
S1	Grill safety micro switch => standard closed
Y1	Water solenoid valve 230V/50Hz 1a output
Y2	Mobile flap connection 230V/50Hz 1A output voltage
L-N	230V/50Hz power supply

Controls – overview options: EKWHCTRL(0/1)(A)

Material	Description	Image
EKWHCTRL0	On board controller for EKWHCTRL1	
EKWHCTRL1	SMART LCD wall controller with temperature probe, white casing	
EKWHCTRL1A	SMART LCD wall controller with temperature probe and IAQ sensor, white casing	

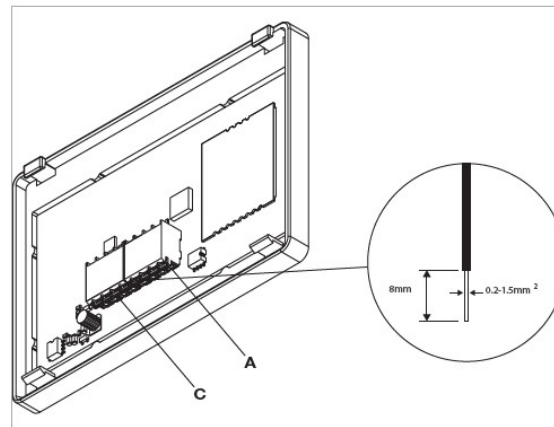

- ✓ Easy to configure
- ✓ Operating in modulating principle
- ✓ Heating and cooling mode
- ✓ IAQ possible



Install the wall hung controller away from doors and/or windows and away from heat emitters and direct sunlight. Best to be placed 1,5m above floor area

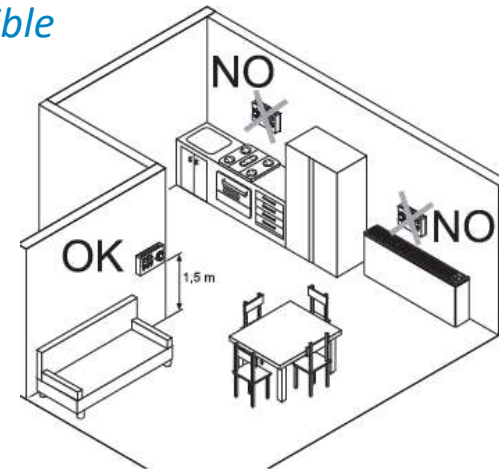

Controls – overview options: EKWHCTRL(0/1)(A) Wiring diagram

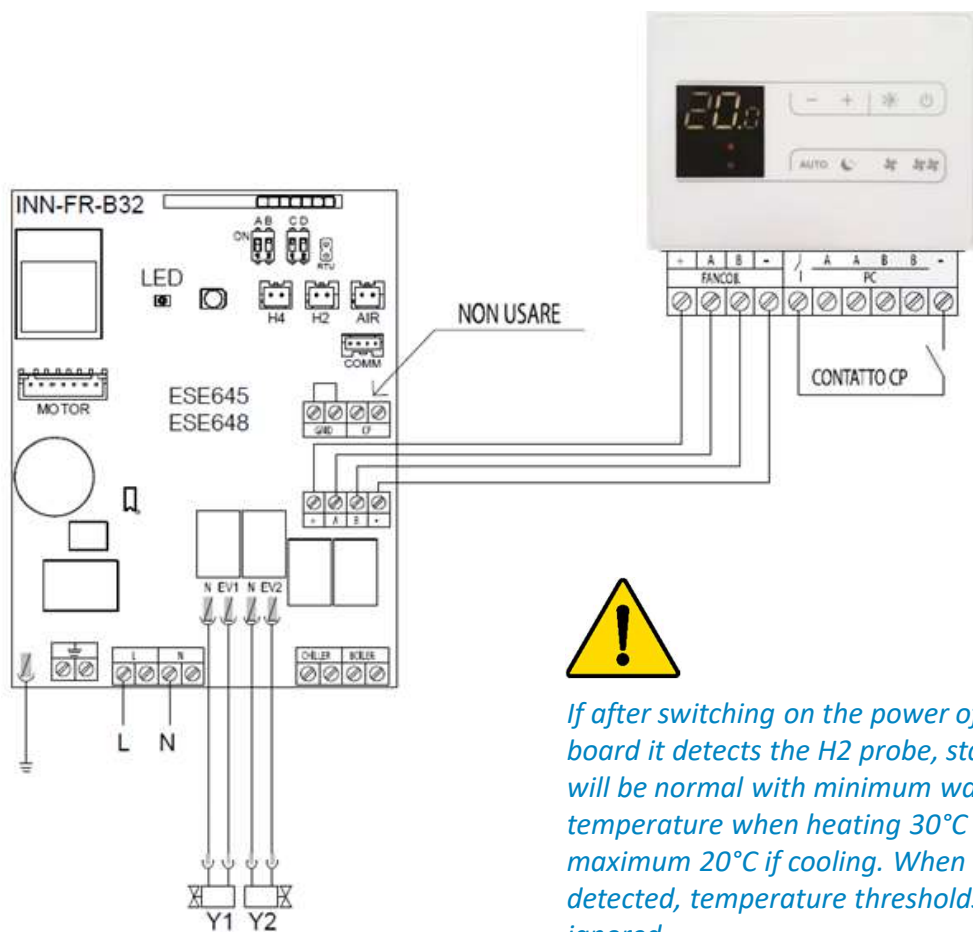

If after switching on the power of the board it detects the H2 probe, start up will be normal with minimum water temperature when heating 30°C and maximum 20°C if cooling. When no H2 is detected, temperature thresholds will be ignored

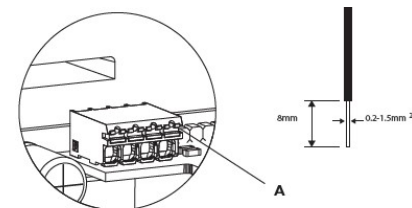





To disconnect the cables, press the corresponding white indent (ref. A) with a screwdriver and remove the conductor.

Part	Description
+AB-	EKWHCTRL1(A) <-> PCB connection
H2	Hot water temperature probe 10kΩ
H4	Not used
AIR	Air temperature probe 10kΩ
MOTOR	DC inverter fan motor
GRID	Grill safety micro switch => standard closed
CP	Presence input sensor (NO contact) // not used
Y1	Water solenoid valve 230V/50Hz 1A output
Y2	Mobile flap connection 230V/50Hz 1A output voltage Relay contact for damper kit
L-N	230V/50Hz power supply
BO	Boiler consent output (free contact max 1A)
CH	Chiller consent output (free contact max 1A)

Controls – overview options: EKPCBO

Material	Description	Image
EKPCBO	On board 4 speeds control switch to be combined with external thermostats	

	Minimum speed selected
	Medium speed selected
	Maximum speed selected
	Supersilent function selected
	Fan coil off or TA contact open (flashing)

Display + Controller integrated

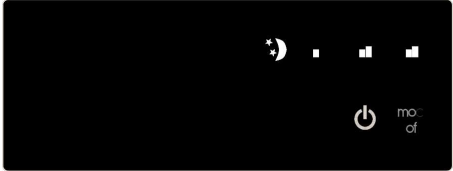

TOP side

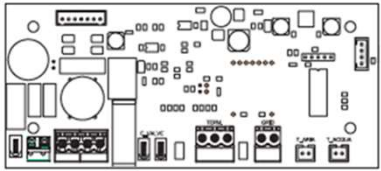

BOTTOM side

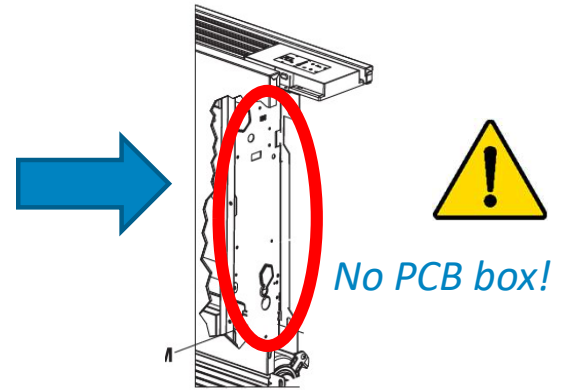
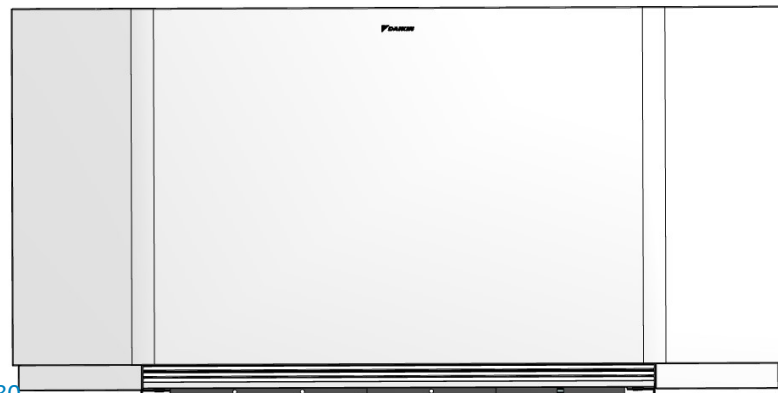

Controls – overview options: EKPCBO Wiring diagram

Remembers last fan speed

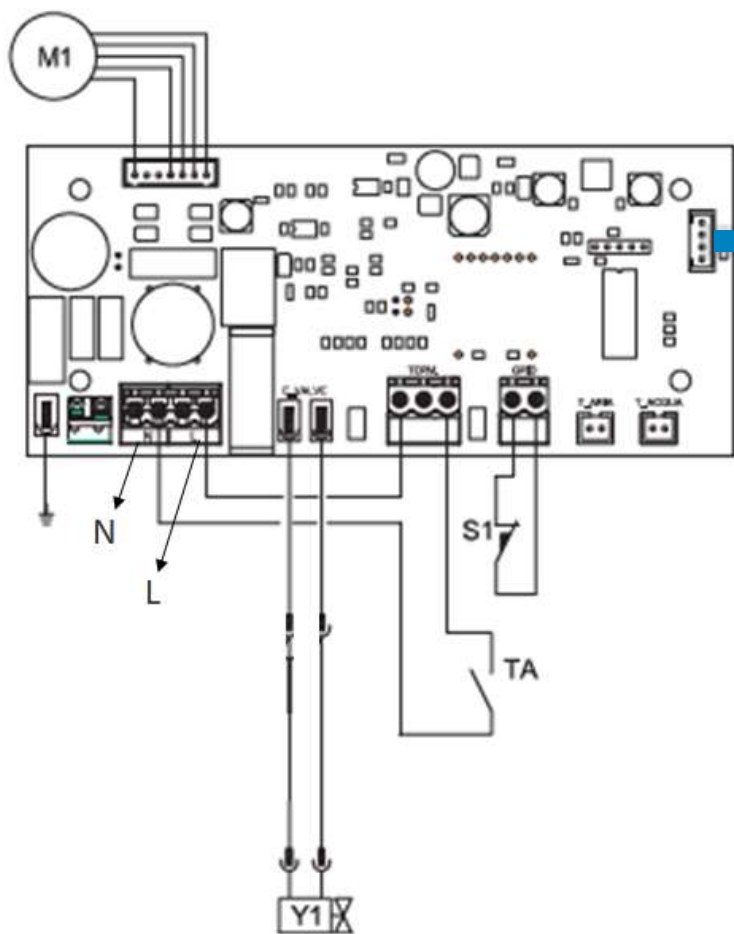

Part	Description
TA	230V connection permission from on/off room thermostat
M1	DC inverter fan motor
S1	Grill safety micro switch => standard closed
Y1	Water solenoid valve (230V/50Hz 1a output)
L-N	230V/50Hz power supply
FF	Output for mobile suction panel (power output 230V/50Hz 1A)

Controls – overview options: EKPCB4S

Material	Description	Image
EKPCB4S	On board PCB for 4 speed control to be combine with 3rd party 3 or 4 speed thermostats	

This on-board PCB allows to set the motor speed through a 3rd party 3 or 4 speed thermostat (not supplied)
Up to 30 HPC's can be connected to the 3rd party thermostat

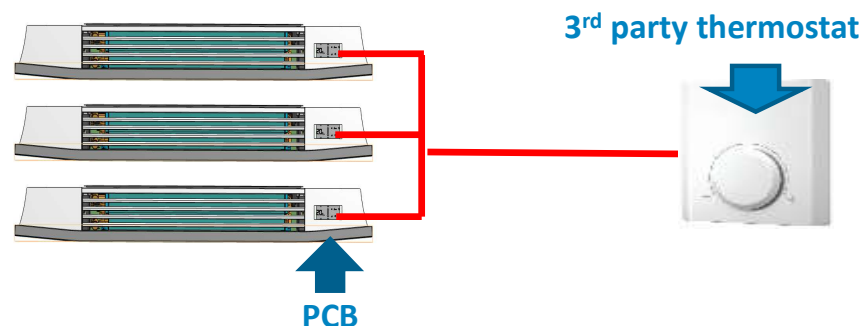

Controls – overview options: EKPCB4S Wiring diagram

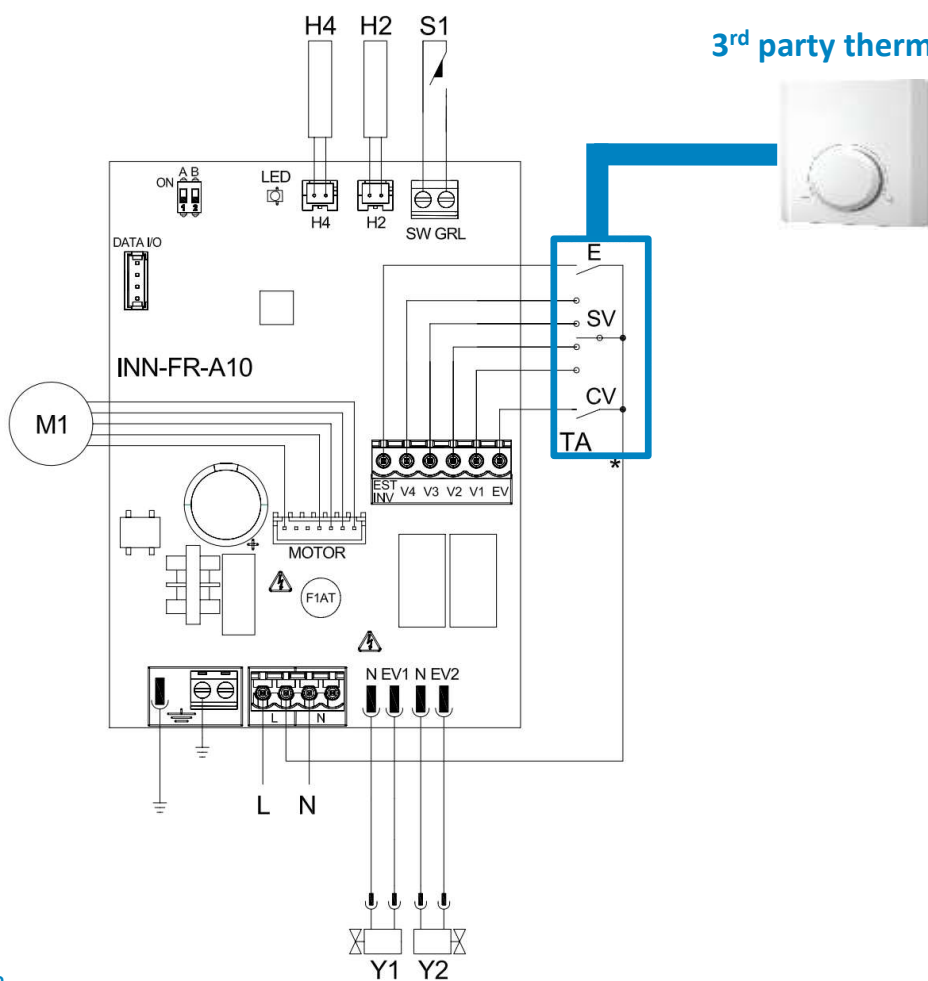

3rd party thermostat

Part	Description
L-N	230V-50Hz power supply
Y1	hot water solenoid valve (230 V / 50 Hz 1 A voltage output)
Y2	not used
M1	DC Inverter fan motor
S1	micro switch for grid safety
H2	water temperature probe (10 kΩ)
H4	not used
TA	3 rd party (3 or 4 speed) thermostat (not supplied) + possible selection of heating / cooling thermostat
E	→ EST/INV: heating, cooling selection input
SV	thermostat speed switch → V1: maximum fan speed → V2: average fan speed → V3: minimum fan speed → V4: super silent speed
CV	→ EV : common thermostat speed selection



Controls – overview options: EKPCB10

Material	Description	Image
EKPCB10	On board PCB for 1-10V speed control to be combine with 3 rd party 10V thermostats	

This on-board PCB allows to modulate the motor speed through a 3rd party 1-10V thermostat (not supplied)
Up to 30 HPC's can be connected to the 3rd party thermostat

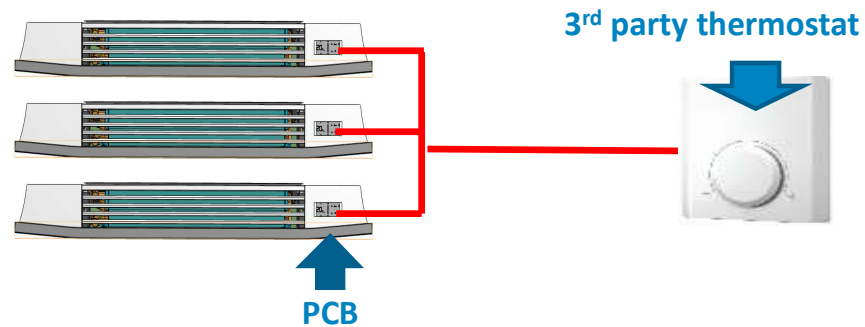

Controls – overview options: EKPCB10 Wiring diagram

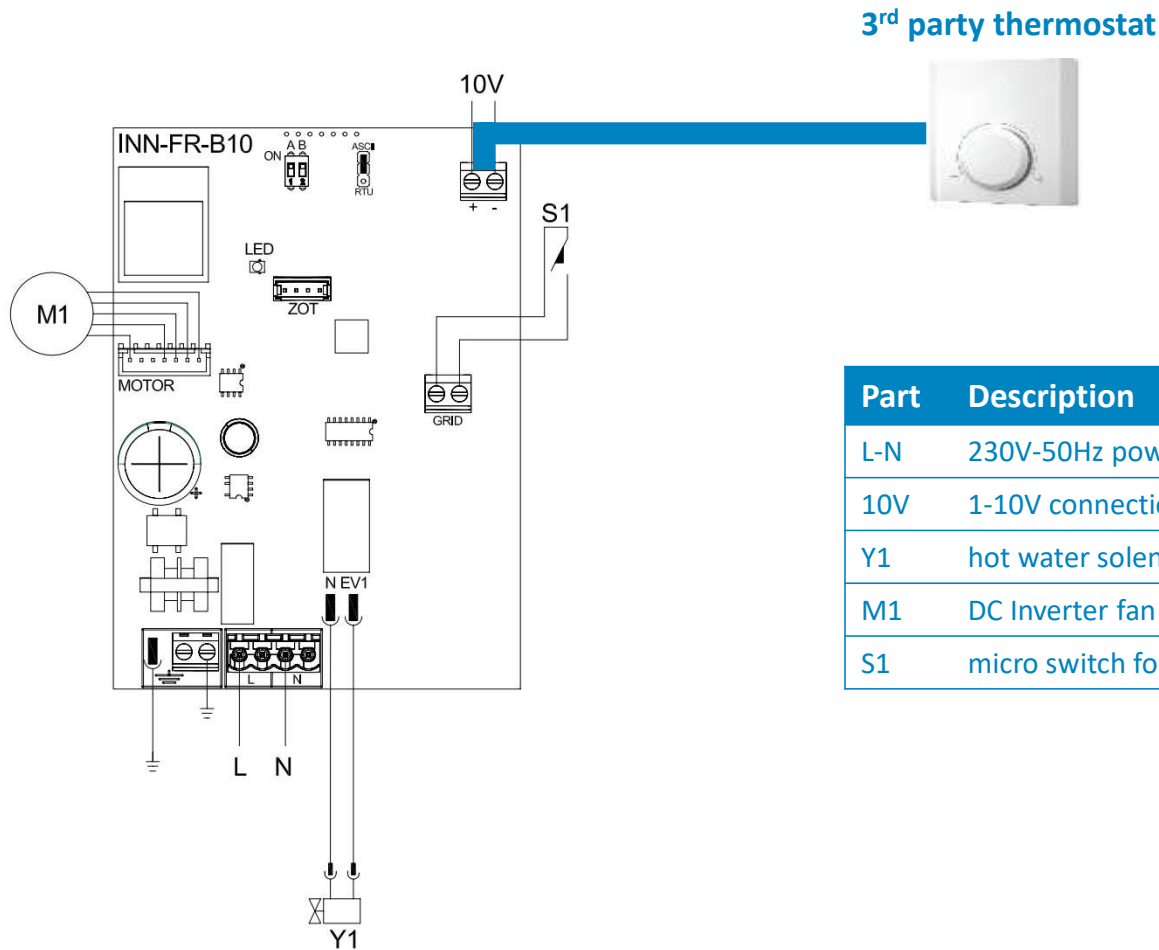

Part	Description
L-N	230V-50Hz power supply
10V	1-10V connection to 3 rd party thermostat (not supplied)
Y1	hot water solenoid valve (230 V / 50 Hz 1 A voltage output)
M1	DC Inverter fan motor
S1	micro switch for grid safety

Controls – overview options: EKFC80 – damper kit for FA supplied through an HRV

Material	Description	Image
EKFC80	Damper kit for FWXV always in combination with controller EKWHCTRL1A	

Purpose:

1. Measure the IAQ – EKWHCTRL1A measures the CO2 and VOC
2. Depending on level of CO2 and VOC, decide if FA is needed yes/no
3. Condition (heat/cool) the FA supplied through an HRV

Restrictions

Always to be used with HRV which supplies the FA.

In step 1, there's no integration with the HRV system. Therefore the FA amount supplied through HRV system need to be **lower than 25%** of the total FA amount of the HRV system.

2 examples to explain the restrictions:

Ex. 1:

Ventilation system tuned at 250 m³/h

2 HPC's connected, FA supply through each HPC = 25 m³/h => 50 / 250 = 20 %

=> **OK**

Ex. 2:

Ventilation system tuned at 250 m³/h

3 HPC's connected, FA supply through each HPC = 35 m³/h => 105 / 250 = 42 %

=> **NoGo**

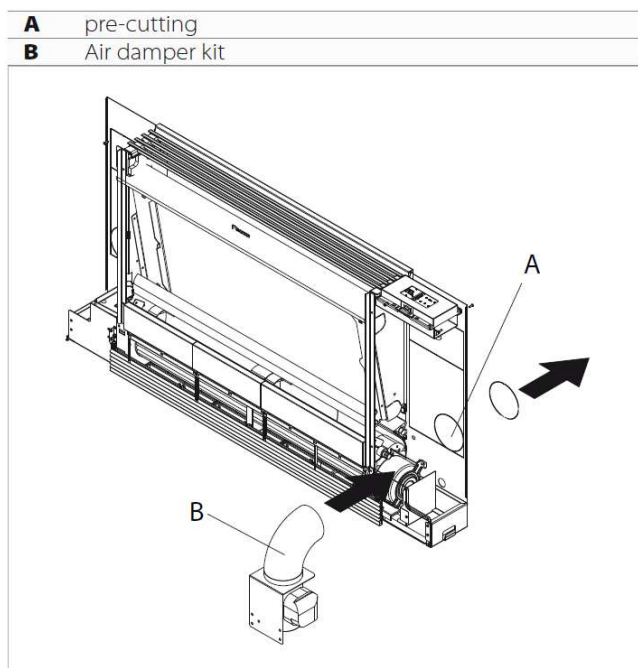

Controls – overview options: EKFC80 Wiring diagram

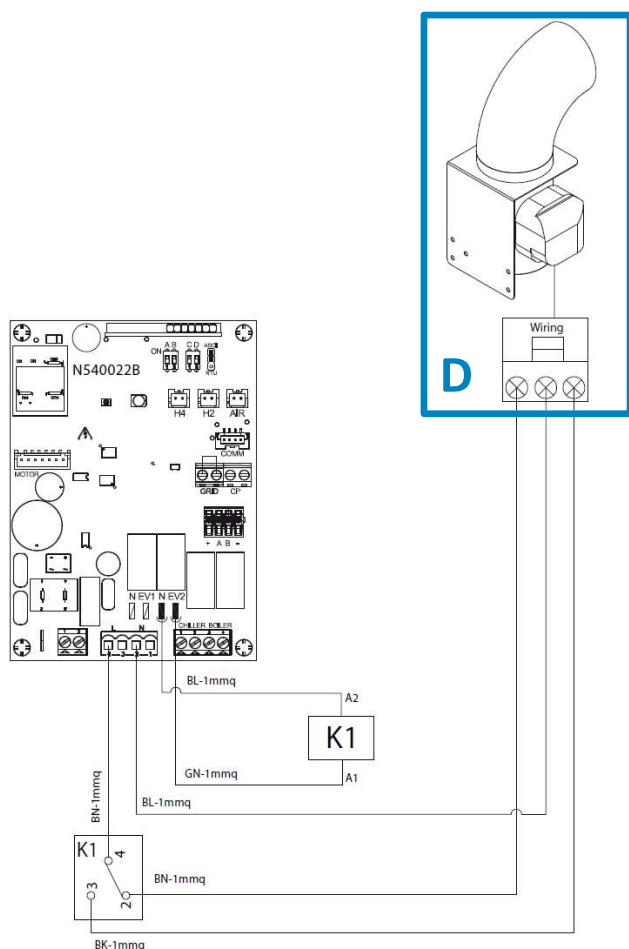

Part	Description
L-N	230V-50Hz power supply 230V connection to K1 and damper
K1	Relay 230V
D	Damper
H2	Hot water temperature probe 10kΩ
H4	Not used
AIR	Air temperature probe 10kΩ
MOTOR	DC inverter fan motor
GRID	Grill safety micro switch => standard closed
CP	Presence input sensor (NO contact) // not used
N EV1	Y1: Water solenoid valve 230V/50Hz 1A output
N EV2	Y2: Relay contact for damper kit

2.5. MODbus explained



MODbus explained - Compatibility table fan coils to MODbus

model	controller	MODbus connection is made on	Reference on PCB	Schematic
FWXV	EKRTCL1	+AB- connector on EKWHCTRL0	N540022B	Diagram B
	EKWHCTRL1(A) + EKWHCTRL0	AABB connector on EKWHCTRL1(A)	EKWHCTRL0: N540022B EKWHCTRL1(A): RN550140A299 (RN550141A299)	Diagram A
	3rd party MODbus controller	+AB- connector on EKWHCTRL0	EKWHCTRL0: N540022B	Diagram C
FWXM	EKWHCTRL1 + EKWHCTRL0	AABB connector on EKWHCTRL1(A)	EKWHCTRL0: N540022B EKWHCTRL1(A): RN550140A299 (RN550141A299)	Diagram A
	3rd party MODbus controller	+AB- connector on EKWHCTRL0	EKWHCTRL0: N540022B	Diagram C
FWXT*	EKWHCTRL1	AABB connector on EKWHCTRL1(A)	PCB in FWXT: N540022B EKWHCTRL1(A): RN550140A299 (RN550141A299)	Diagram A
	3rd party MODbus controller	+AB- connector on EKWHCTRL0	PCB in FWXT: N540022B	Diagram C

* FWXT-C is **not** compatible with MODbus

PCB needs to be N540022B

!! Changing FWXV/M + EKWHCTRL1(A) (= [diagram A](#)) to FWXV/M + MODbus controller (= [diagram B](#)/[diagram C](#)) is not possible.

MODbus explained - General info

Type of cable: bipolar shielded cable suitable for the RS485 serial connection with a minimum section of 0,35 mm²

Cable length: max. 500m

Protocol: MODbus RTU (on-board jumper **A** closed at power-up)

Communication: Serial: 9600-8-N-1 (line speed [bits/s] – data bits – parity bit [N=no] – stop bit)

Default MODbus address of devices = 1

Each device on MODbus requires a unique address

2 different connectors are used to connect the HPC to the MODbus:

Connector	Where to find	In combination with controller
AABB-	EKWHCTRL1(A)	HPC + EKWHCTRL1(a)
+AB-	EKWHCTRL0	HPC + EKRTCTRL1/2 or without controller

Pin layout + connection to MOD bus

+AB-		MODbus
pin	connection	pin
+	open	
A	to	A (signal)
B	to	B (signal)
-	open	
	open	C (GND)

AABB		MODbus
pin	connection	pin
	open	
A	to	A (signal)
A	open	
B	to	B (signal)
B	open	
-	open	
	open	C (GND)

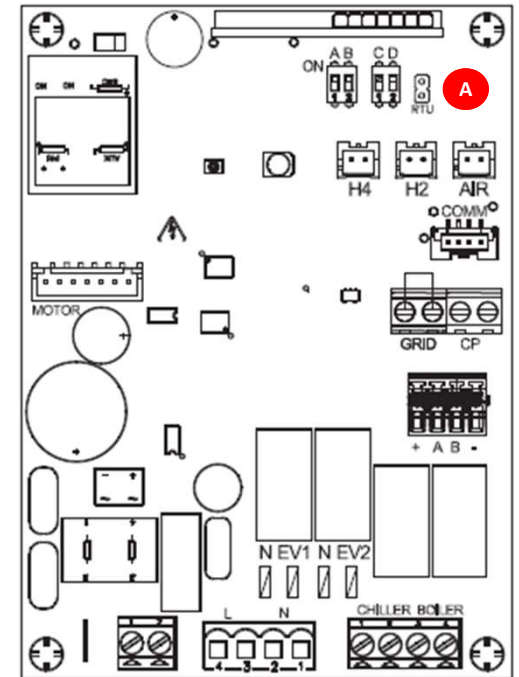



MODbus explained – Device address setting

To view and change the address

Solution 1: using the EKRTCTRL1

Set/view address using the EKRTCTRL1

With the panel in standby, press and hold the 'AUTO' key for 5s.

Current address appears flashing (default = 001)

Change address using the '+' and '-' key (range 1 to 255; **but do not use 1**)

Press the 'STANDBY' key or wait 10s to confirm the setting

Solution 2: using the EKWHCTRL1(A)

Set/view address using the EKRTCTRL1

Make sure only 1 HPC is connected to the EKWHCTRL1(A)

With the panel in standby, press and hold the 'AUTO' key for 5s.

Current address appears flashing (default = 001)

Change address using the '+' and '-' key (range 1 to 255; **but do not use 1**)

Press the 'STANDBY' key or wait 10s to confirm the setting

!! Remark: Each fan coil needs a unique address.

HINT: Keep track of addresses!

Address	Where to find
000	DO NOT USE <small>(broadcast address)</small>
001	DO NOT USE
002	HPC Kitchen
003	HPC Living room
004	HPC Master bedroom
...	...



MODbus explained – diagram A: connection FWXV/M/T + EKWCTRL1(A)

All HP convectors are directly connected to EKWCTRL1(A), EKWCTRL1(A) is connected to MODbus
MODbus is connected to AABB connector on EKWCTRL1(A).

HP convectors need no address, EKWCTRL1(A) needs MODbus address.

RTU jumper opened

Max. 30 HP convectors to 1 display

To establish the connection, we refer to [‘Annex 3: remote mode for FWXV/M/T fan coil commands’](#)

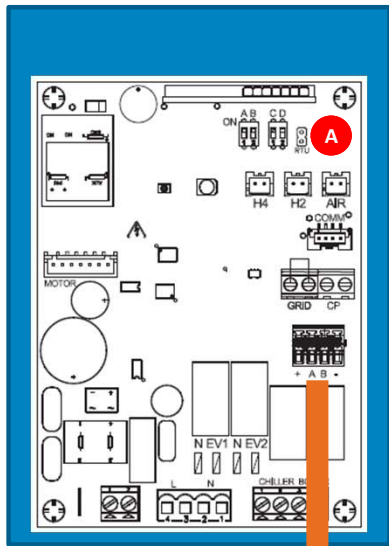

ASCII MODbus

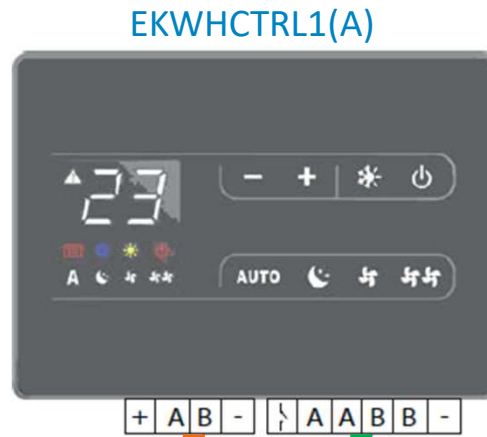
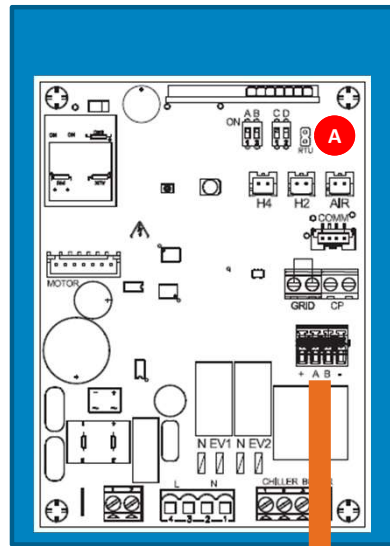

RTU MODbus

A: RTU connector OPENED at power

ASCII MODbus: 9600-7-E-1

MODbus explained – diagram B: connection FWXV + EKRTCTRL1

All HP convectors are directly connected to the MODbus

Each fan coil needs an MODbus address. Default address is 1. It needs to be changed and each HP convector must have a unique address, MODbus address can be set with control panel.

MODbus is connected to +AB- connector of the PCB

operating the EKRTCTRL1A will set the new value until the timer in register XXX is expired. When register XXX is set on 0, time is infinite.

To establish the connection, we refer to [‘Annex 3: remote mode for FWXV/M/T fan coil commands’](#)

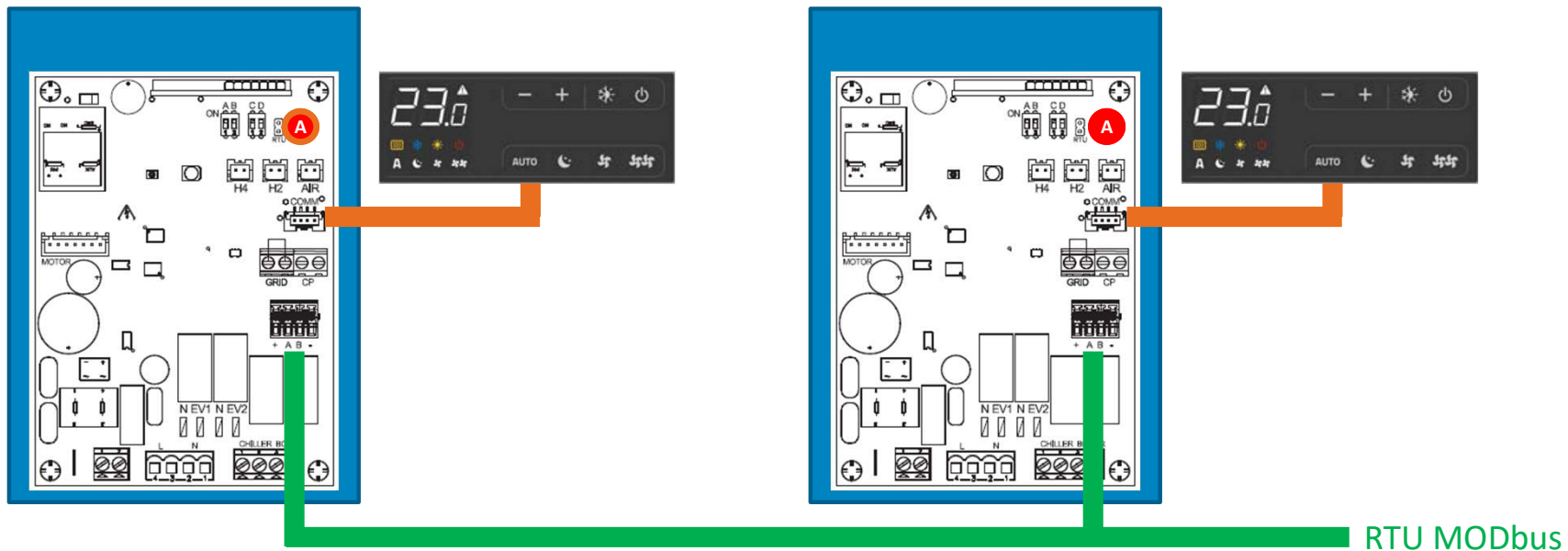

A: RTU connector closed at power up – use jumper included in box

RTU MODbus

MODbus explained – diagram C: connection FWXV/M/T direct

All HP convectors are directly connected to the MODbus

Each fan coil needs an MODbus address. Default address is 1, but needs to be changed and each HP convector must have a unique address. MODbus address can be set with MODbus controller or alternative with spare controller EKRTCTRL1. => fan coil address needs to be different from 1.

MODbus is connected to +AB- connector of the PCB

!! HPC needs air temperature. There are 2 ways to supply it:

Provide separate air probe. It can be ordered as a spare part with spare part number: 5024986

Or write air temp. => **Follow instructions:** [‘Annex 3: remote mode for FWXV/M/T fan coil commands’](#)

- **Set: Register 224.1 (CFG.REM): 1**
- **Write: register 103 (REM_TA): current air temperature**

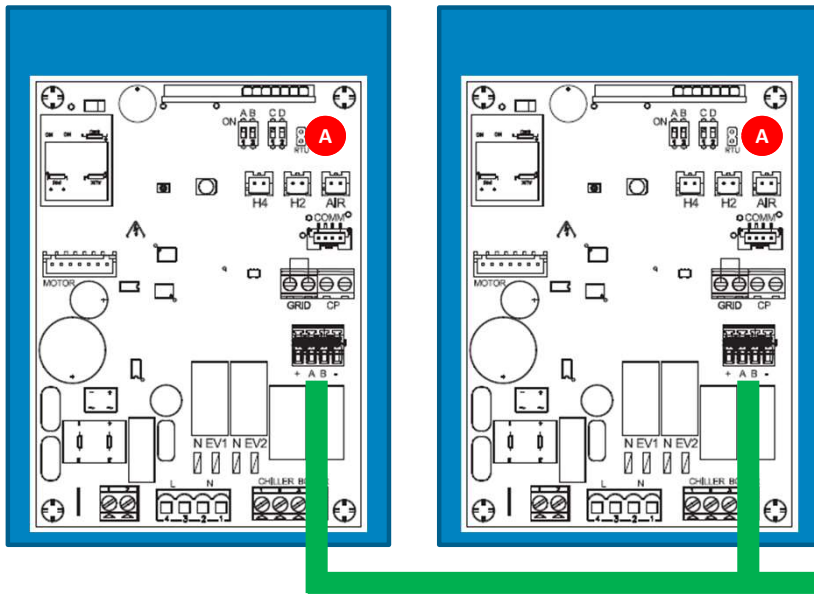

RTU MODbus

A: RTU connector closed at power up – use jumper included in box



MODbus explained – Annexes

Annex 1: [FWXV/M/T fan coil - Modbus interface quick reference](#)

Annex 2: [Parameter PCB board INN-FR-B3X](#)

Annex 3: [remote mode for FWXV/M/T fan coil commands](#)

2.6. Electrical diagrams

Electrical diagrams – examples of installations: FWXV

- [Installation 1 zone - EKWHCTRL1 - EKRTCTRL1](#)
- [Installation 2 zone - EKPCBO – EKRTR](#)
- [Installation 2 zone - EKRTCTRL1 - BRC1HHD](#)
- [Installation 2 zone - EKRTCTRL1 - EKRTR](#)

Legend

- A Unit Indoor Single zone unit
- B EKWHCTRL1 SMART LCD wall controller with temperature probe
- Ba EKWHCTRL0 white casing; connecting up to 30 HPC units
- C HPC Heat pump convector Floor standing FWXV
- D EK2VK0 Motorized 2-way valve
- E EK3VK1 Motorized 3-way valve
- F EKRTCTRL1 On board electronic control SMART TOUCH with PID full modulating fan and thermostat

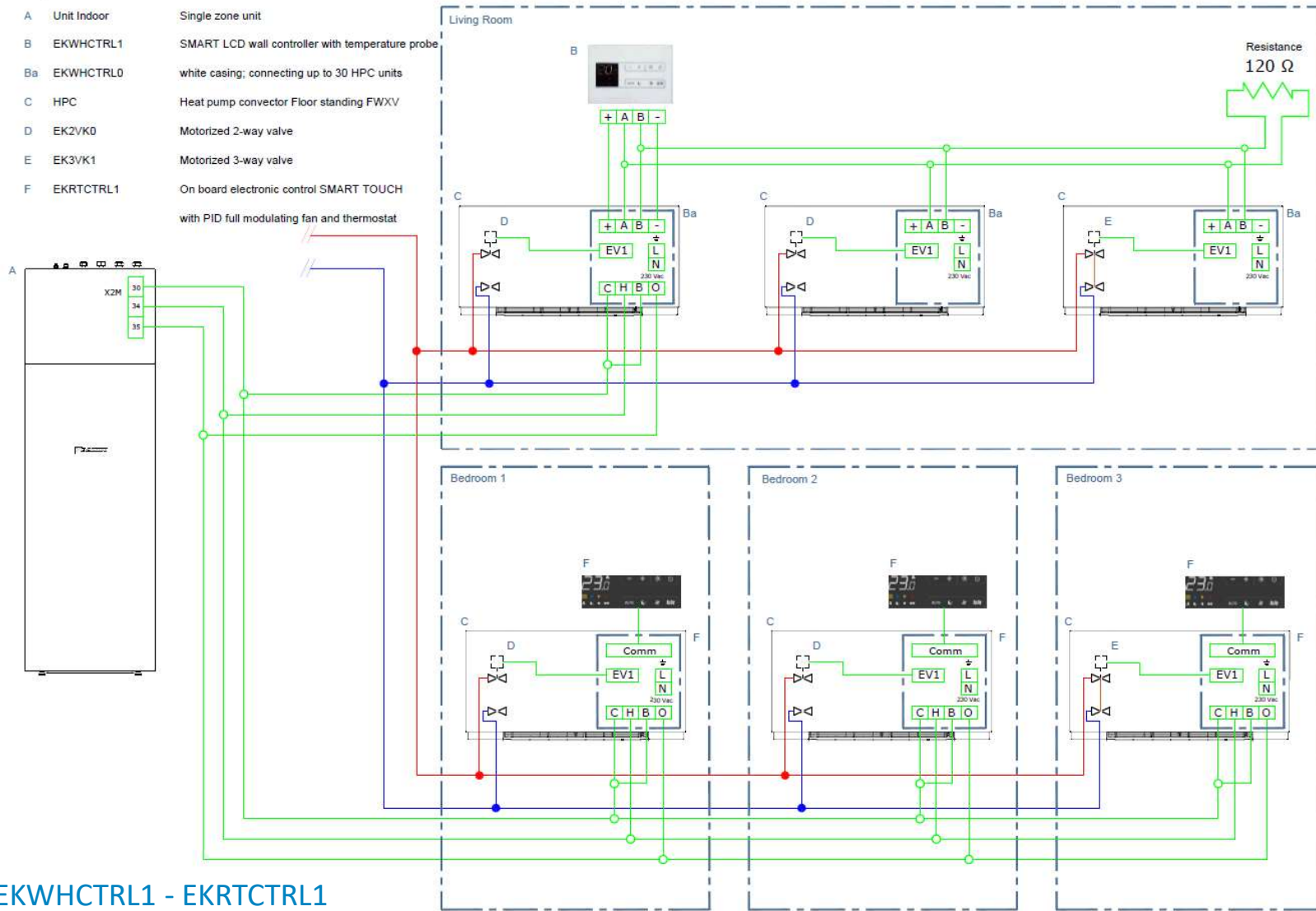

1 zone - EKWHCTRL1 - EKRTCTRL1

Legend

- A Unit Indoor Dual zone unit
- B EKPCBO On board 4 speeds control switch to be combine combinable with on/off thermostats
- C HPC Heat pump convector Floor standing FWXV
- D EK2VK0 Motorized 2-way valve
- E EK3VK1 Motorized 3-way valve
- F EKTRR Thermostat
- G RMX Collector RMX UFH

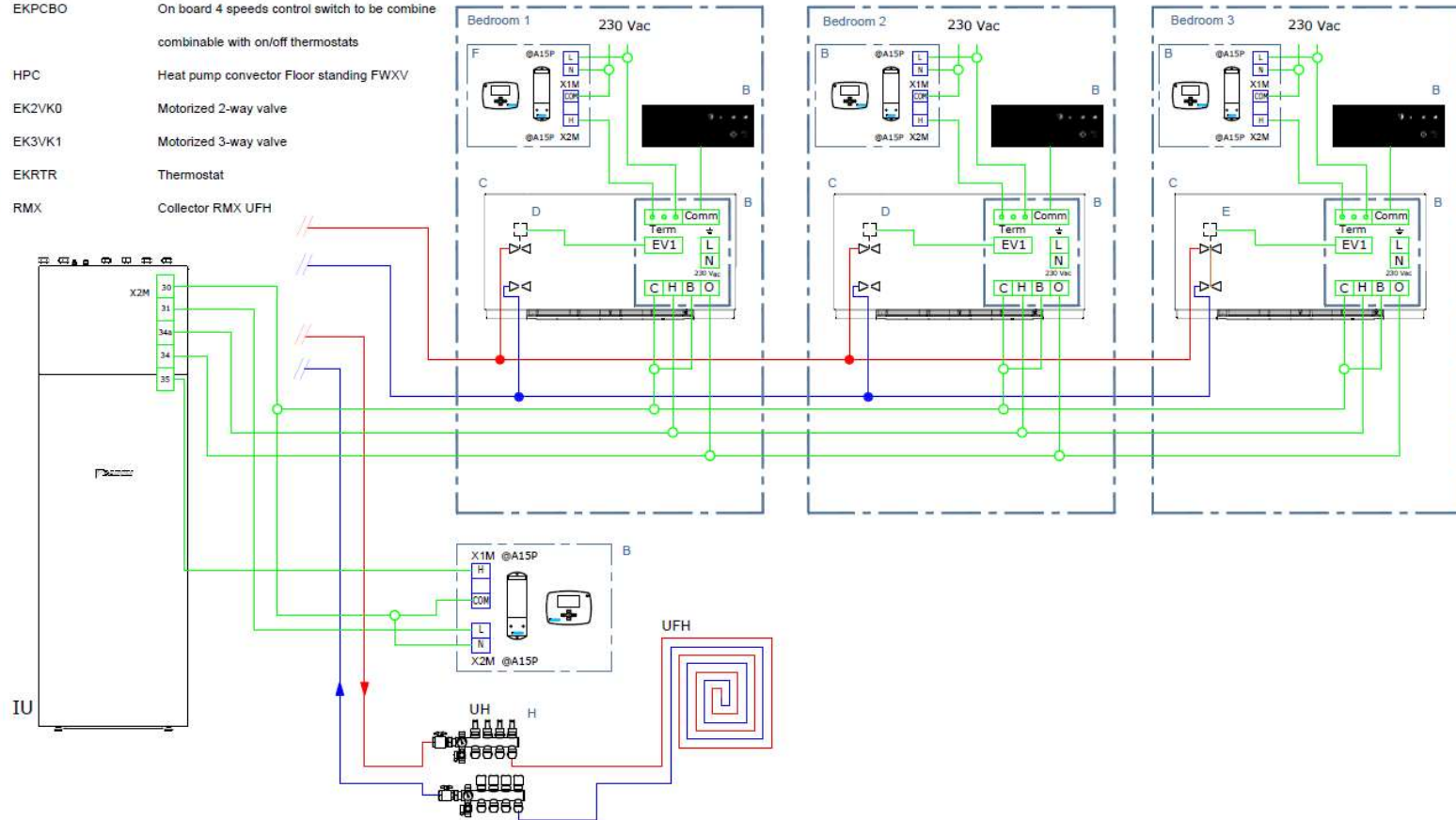

Legend

- A Unit Indoor Dual zone unit
- B EKRTCTRL1 On board electronic control SMART TOUCH with PID full modulating fan and thermostat
- C HPC Heat pump convector Floor standing FWXV
- D EK2VK0 Motorized 2-way valve
- E EK3VK1 Motorized 3-way valve
- F BRC1HHD Madoka Thermostat
- G RMX Collector RMX UFH

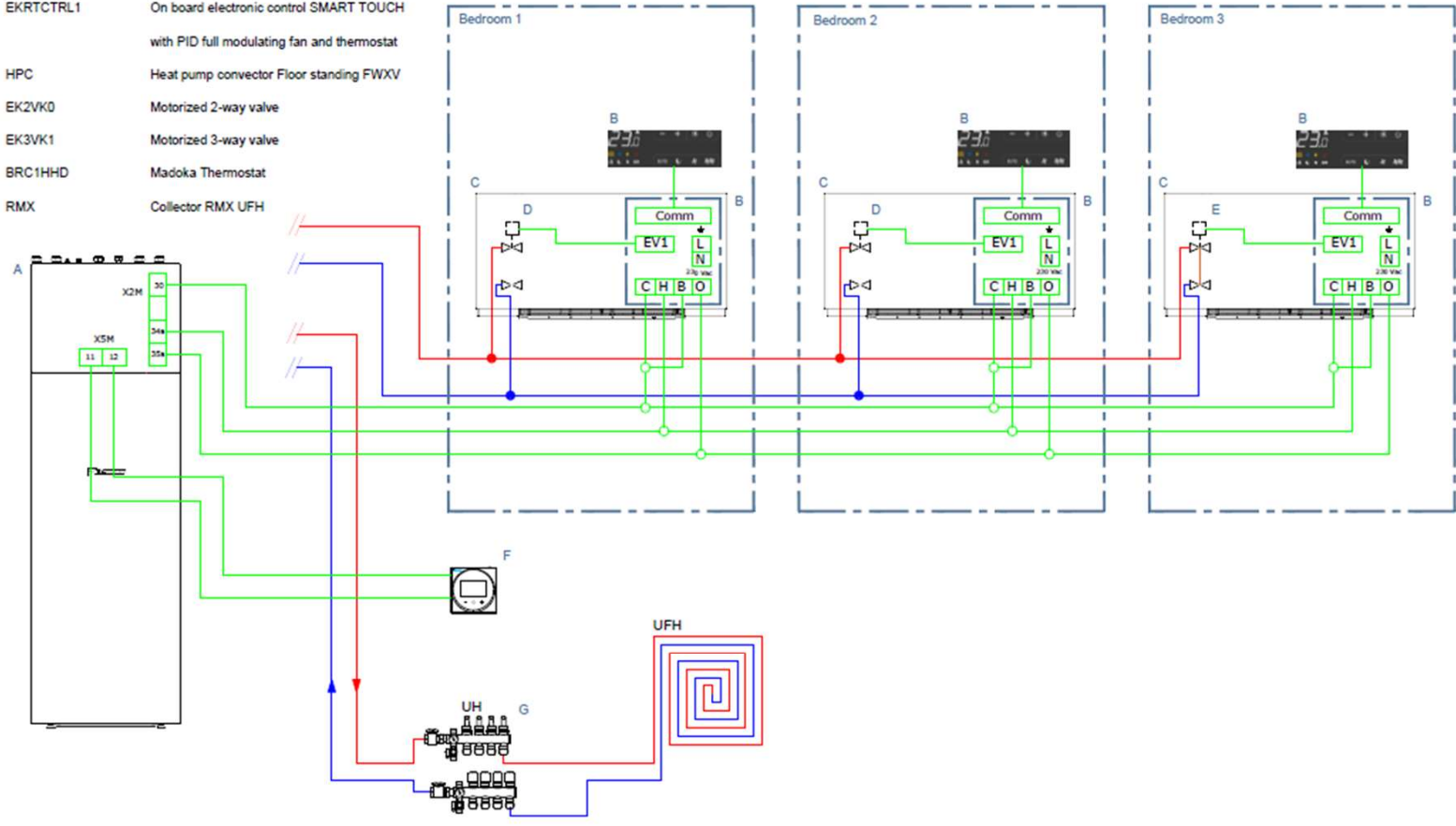

Legend

- A Unit Indoor Dual zone unit
- B EKRTCTRL1 On board electronic control SMART TOUCH with PID full modulating fan and thermostat
- C HPC Heat pump convector Floor standing FWXV
- D EK2VK0 Motorized 2-way valve
- E EK3VK1 Motorized 3-way valve
- F EKTRR Thermostat
- G RMX Collector RMX UFH

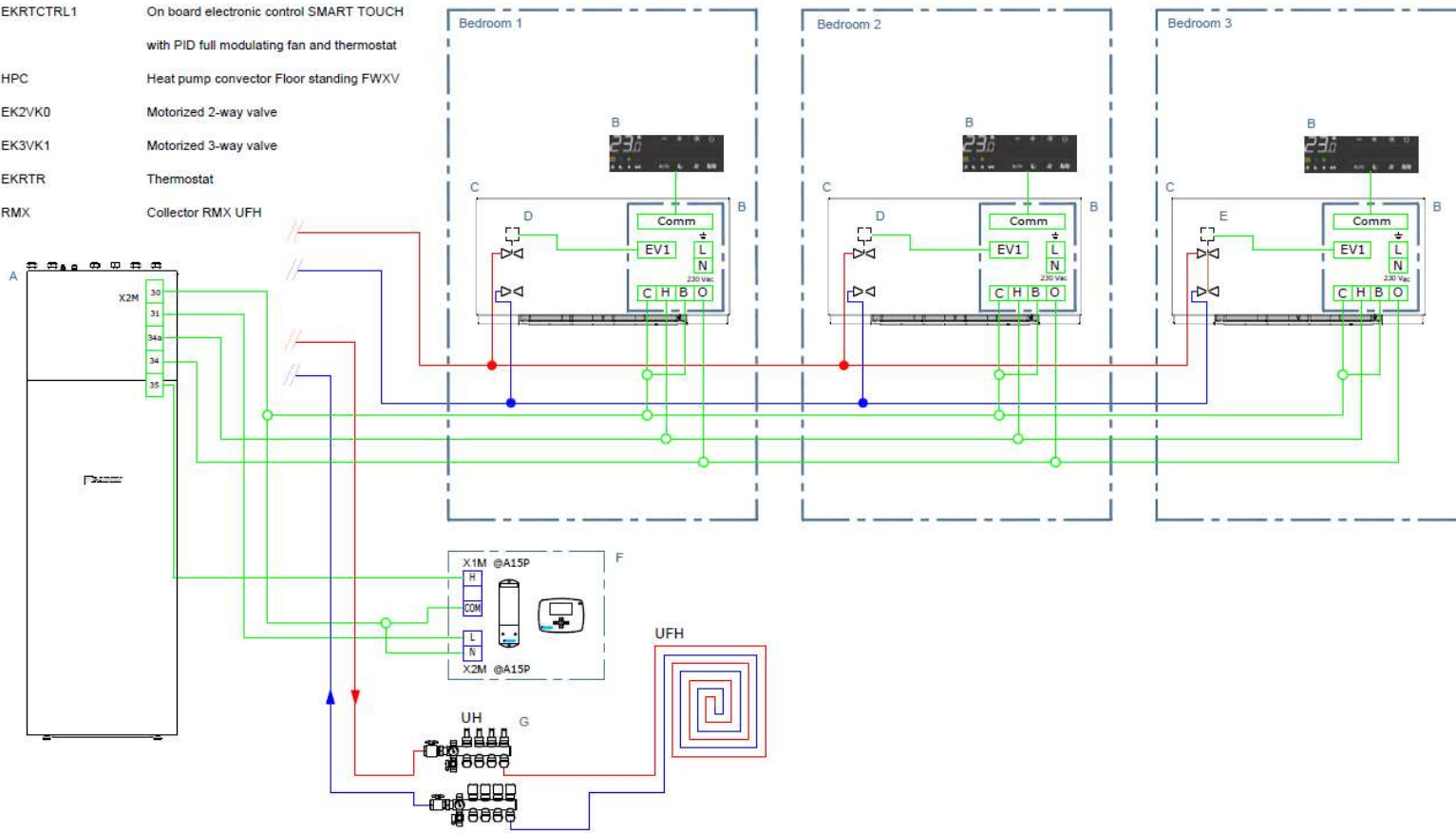

2 zone - EKRTCTRL1 - EKTRR

Electrical diagrams – examples of installations: FWXM

- [Installation 2 zone - EKWHCTRL1 - BRC1HHD](#)
- [Installation 2 zone - EKWHCTRL1.- EKRTR](#)
- [Installation 1 zone - EKWHCTRL1 - EKWHCTRL1](#)

Legend

- | | | |
|----|-------------|--|
| A | Unit Indoor | Dual zone unit |
| B | EKWHCTRL1 | SMART LCD wall controller with temperature probe |
| Ba | EKWHCTRL0 | with PID full modulating fan and thermostat |
| C | HPC | Heat pump convector Integrated FWXM |
| D | EK2VK0 | Motorized 2-way valve |
| E | EK3VK1 | Motorized 3-way valve |
| F | BRC1HHD | Madoka Thermostat |
| G | RMX | Collector RMX UFH |

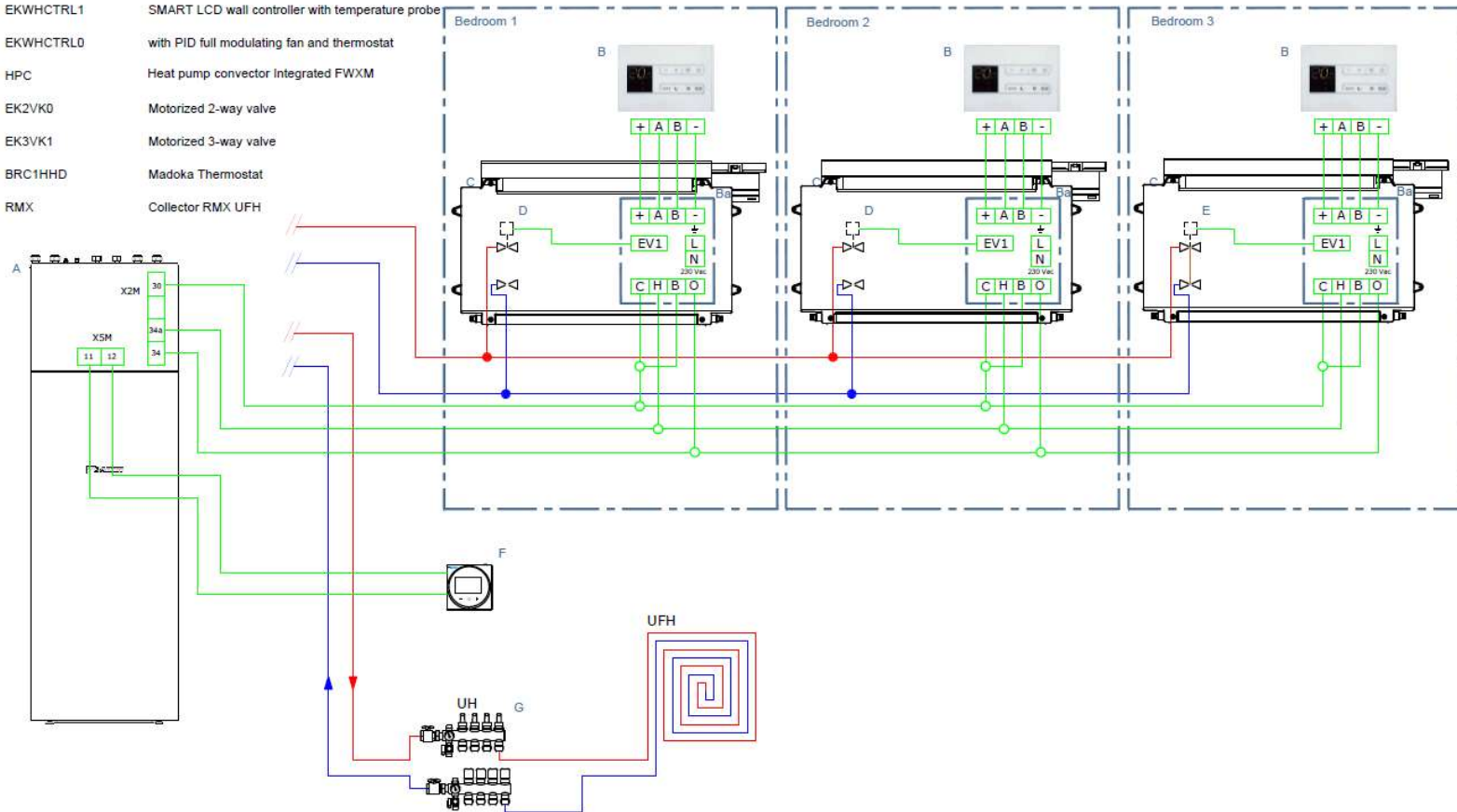

Legend

- A Unit Indoor Dual zone unit
- B EKWHCTRL1 SMART LCD wall controller with temperature probe
- Ba EKWHCTRL0 with PID full modulating fan and thermostat
- C HPC Heat pump convector Integrated FWXM
- D EK2VK0 Motorized 2-way valve
- E EK3VK1 Motorized 3-way valve
- F EKTRR Thermostat
- G RMX Collector RMX UFH

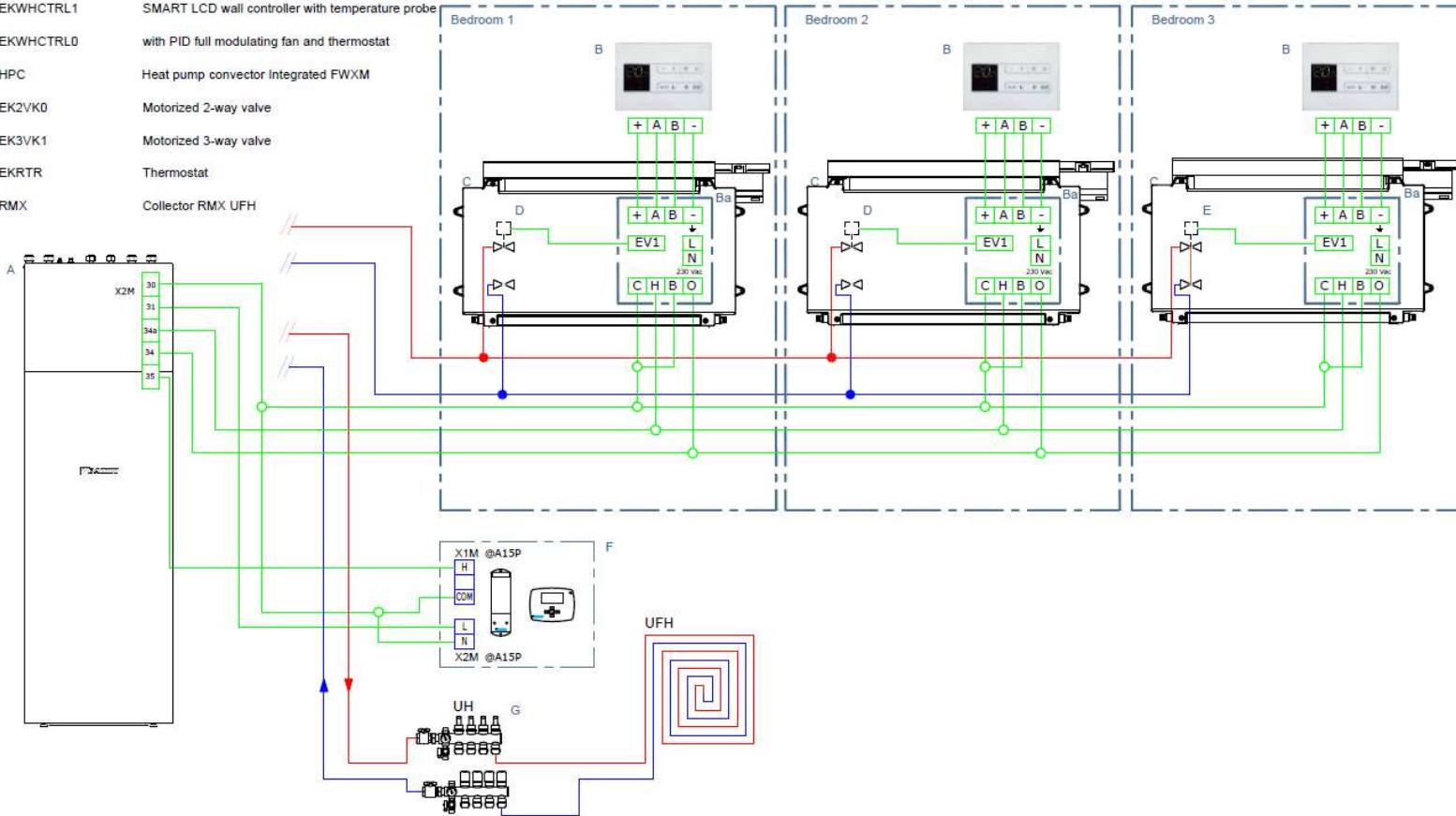

2 zone - EKWHCTRL1.- EKTRR

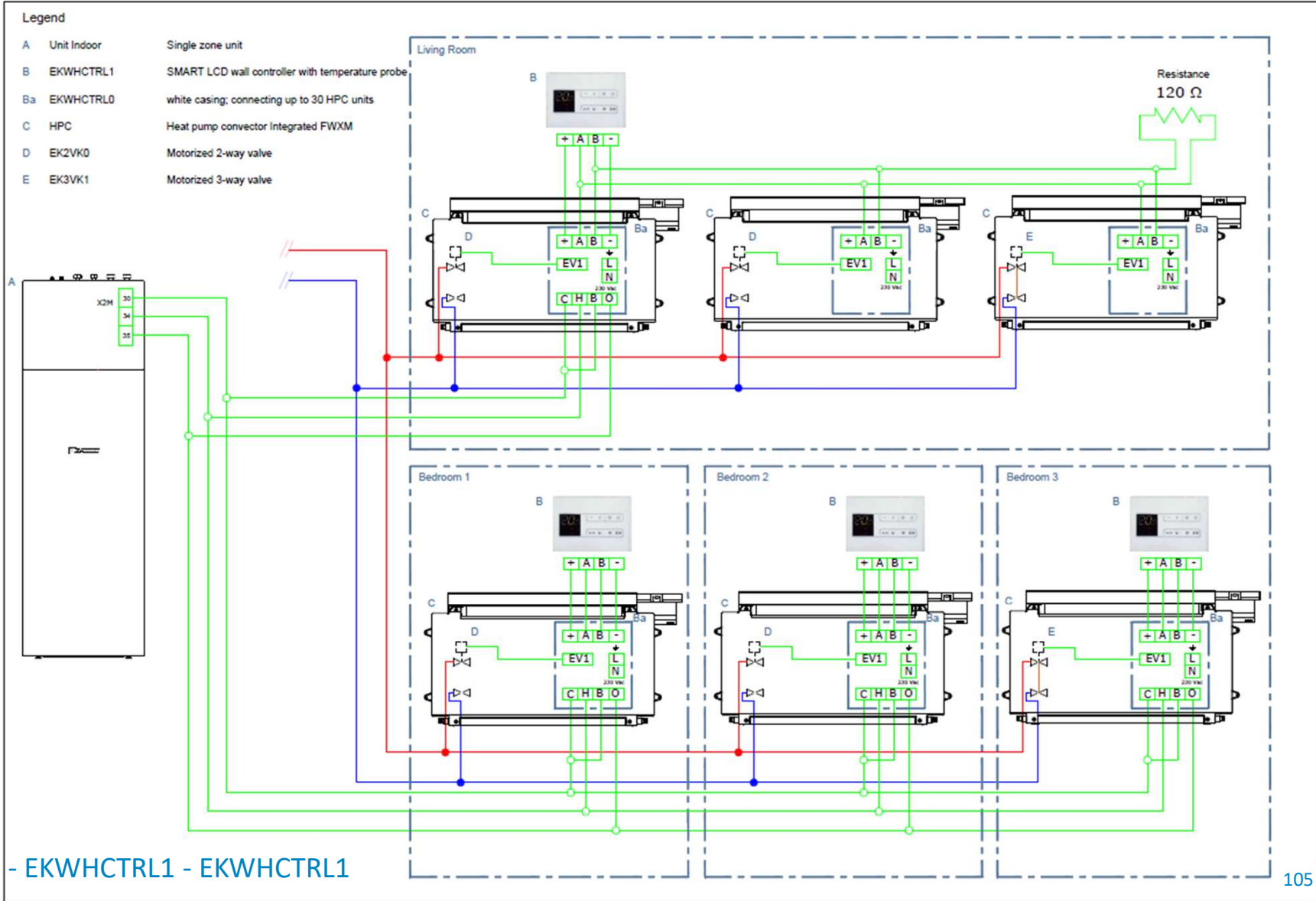

1 zone - EKWHCTRL1 - EKWHCTRL1

Electrical diagrams – examples of installations: FWXT-C

- [Installation 2 zone - BRC1HHD](#)
- [Installation 2 zone - EKRTR](#)

Legend

- | | | |
|---|-------------|-------------------------------|
| A | Unit Indoor | Dual zone unit |
| C | HPC | Heat pump convector Wall FWXT |
| D | EKT2VK0 | Motorized 2-way valve |
| E | EKT3VK1 | Motorized 3-way valve |
| F | BRC1HHD | Madoka Thermostat |
| G | RMX | Collector RMX UFH |
| H | | Remote control |

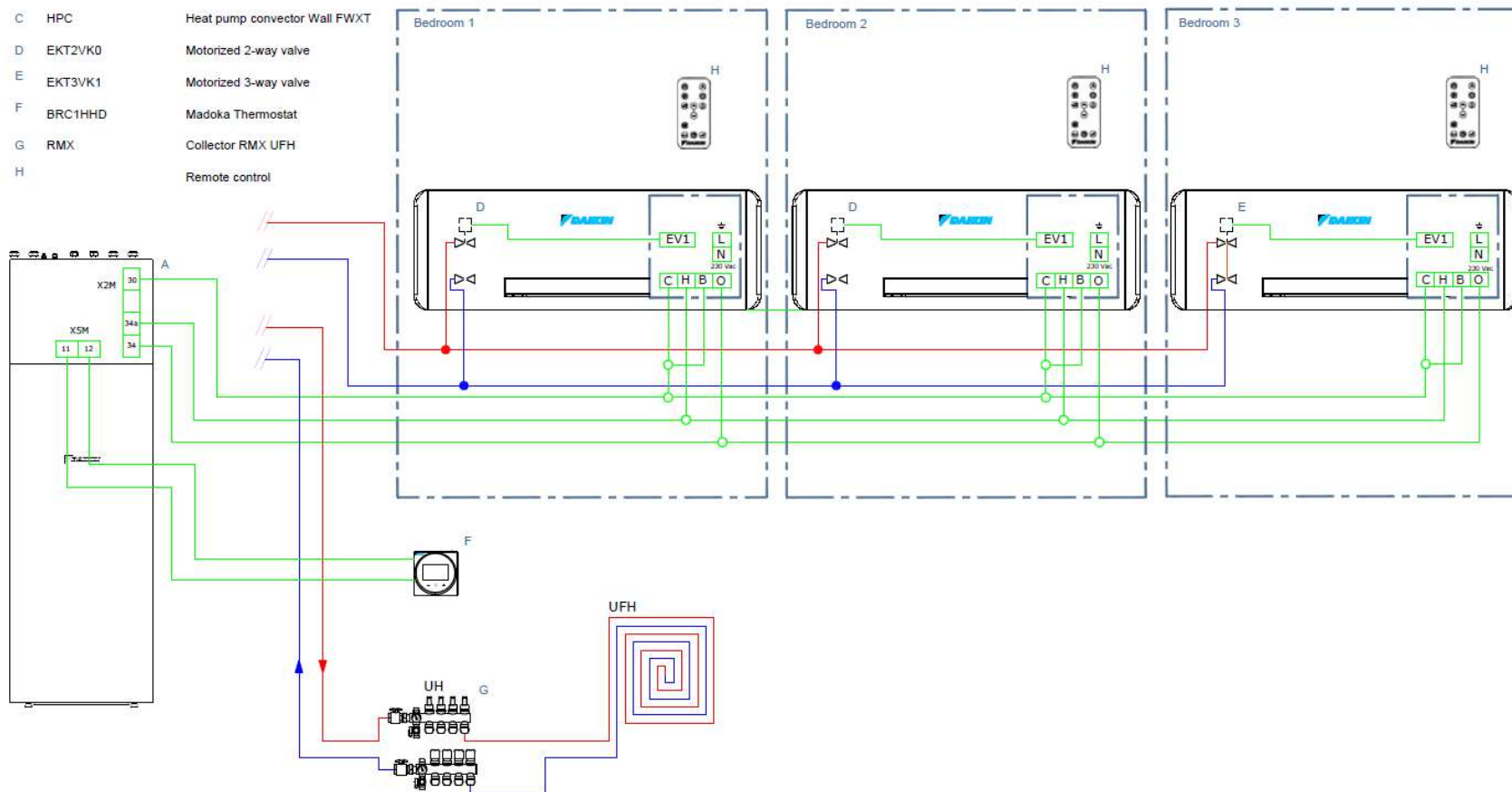

Legend

- | | | |
|---|-------------|-------------------------------|
| A | Unit Indoor | Dual zone unit |
| C | HPC | Heat pump convector Wall FWXT |
| D | EK2VK0 | Motorized 2-way valve |
| E | EK3VK1 | Motorized 3-way valve |
| F | EKRTR | Thermostat |
| G | RMX | Collector RMX UFH |
| H | | Remote control |

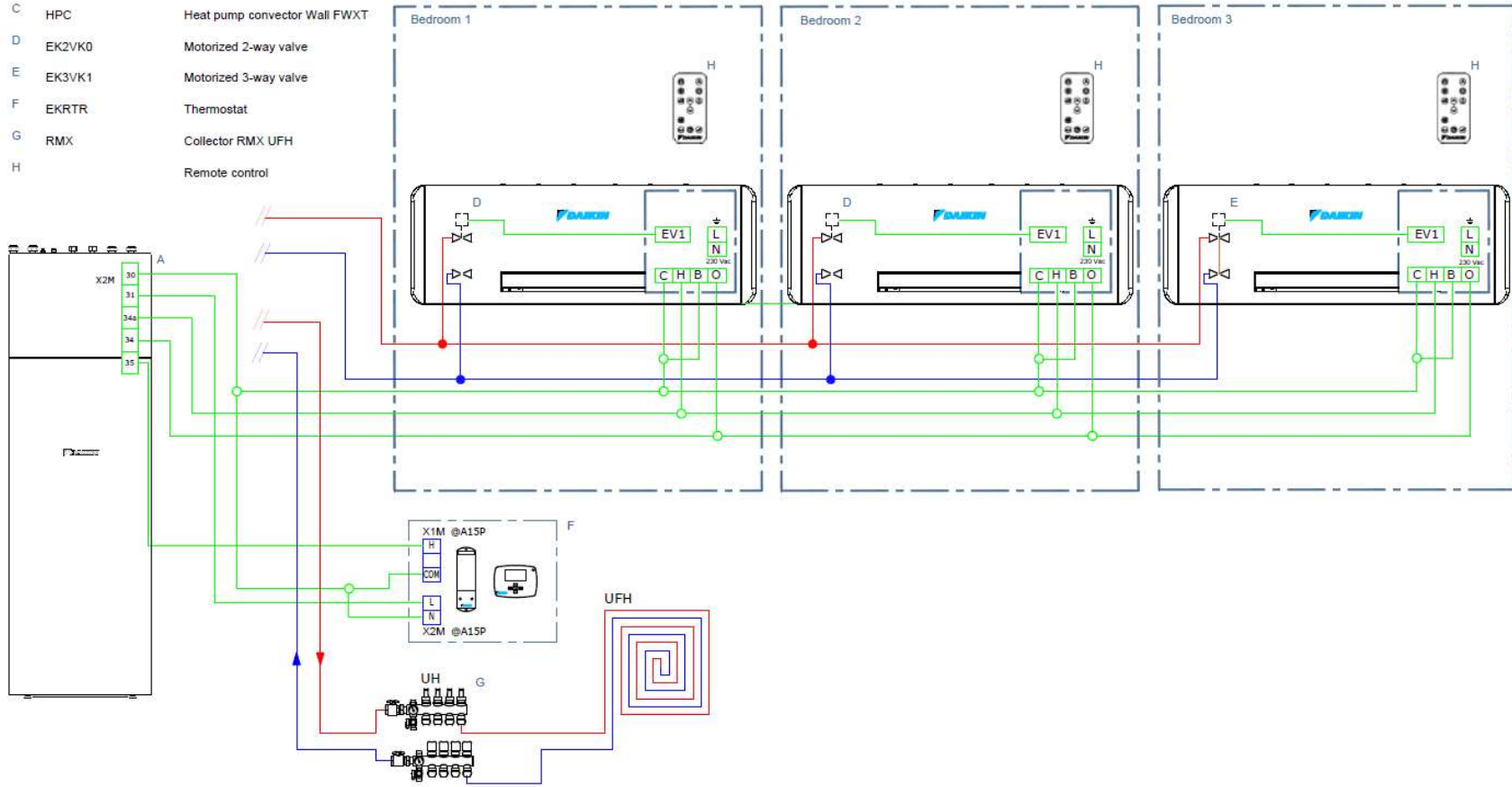

2.7. Product naming

Product naming

FWX ¹⁰
¹⁵
²⁰ V
M
T A A T V3 (C) (L/R)



- (L/R): optional: nonstandard hydraulic connection
- (C): optional: IR remote control
- V3: 1 fase / 230V / 50Hz
- T: 2 pipe system
- A/B: minor model change
- A: major model change
- 10/15/20: capacity/size
- V/M/T: V: floor standing / M: concealed / T: high wall
- FWX: heat pump convector

2.8. Manuals

Manuals: FWXV/FWXM/FWXT

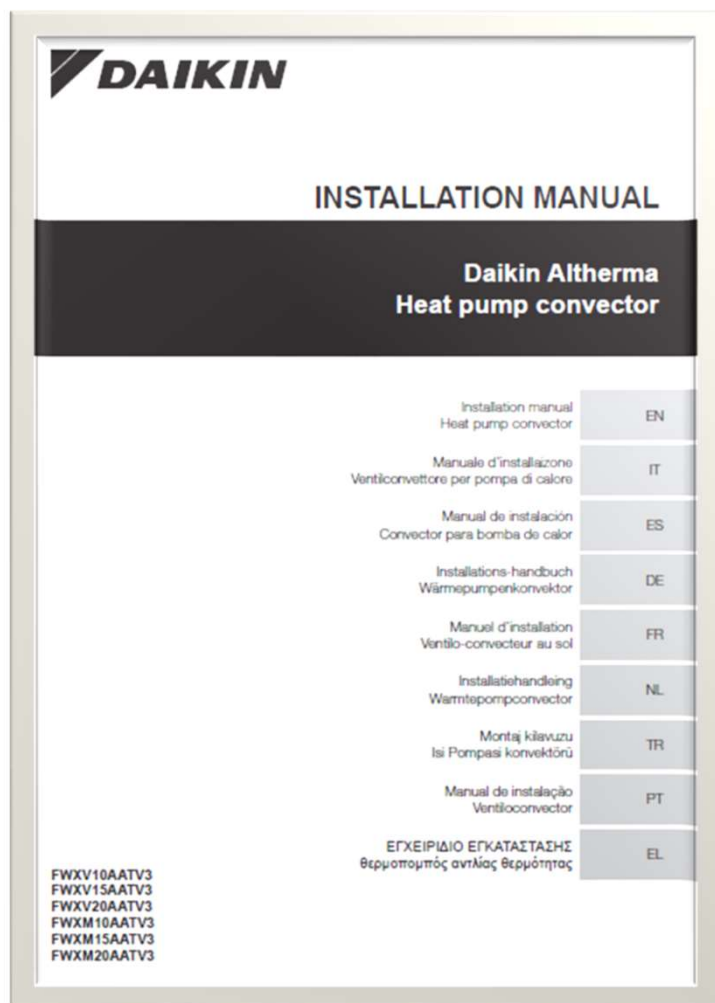

Language	Packed with unit (STC)	Only online (DOD)
English	STC	-
Italian	STC	-
Spanish	STC	-
German	STC	-
French	STC	-
Dutch	STC	-
Turkish	STC	-
Portuguese	STC	-
Greek	STC	-
Danish	-	DOD
Swedish	-	DOD
Norwegian	-	DOD
Finnish	-	DOD
Czech	-	DOD
Croatian	-	DOD
Hungarian	-	DOD
Polish	-	DOD
Romanian	-	DOD
Slovenian	-	DOD
Estonian	-	DOD
Bulgarian	-	DOD
Lithuanian	-	DOD
Latvian	-	DOD
Slovak	-	DOD

Manuals: Controllers



Language	Packed with unit (STC)	Only online (DOD)
English	STC	-
Italian	STC	-
Spanish	STC	-
German	STC	-
French	STC	-
Dutch	STC	-
Turkish	STC	-
Portuguese	STC	-
Greek	STC	-
Danish	-	DOD
Swedish	-	DOD
Norwegian	-	DOD
Finnish	-	DOD
Czech	-	DOD
Croatian	-	DOD
Hungarian	-	DOD
Polish	-	DOD
Romanian	-	DOD
Slovenian	-	DOD
Estonian	-	DOD
Bulgarian	-	DOD
Lithuanian	-	DOD
Latvian	-	DOD
Slovak	-	DOD

Manuals: Additional options

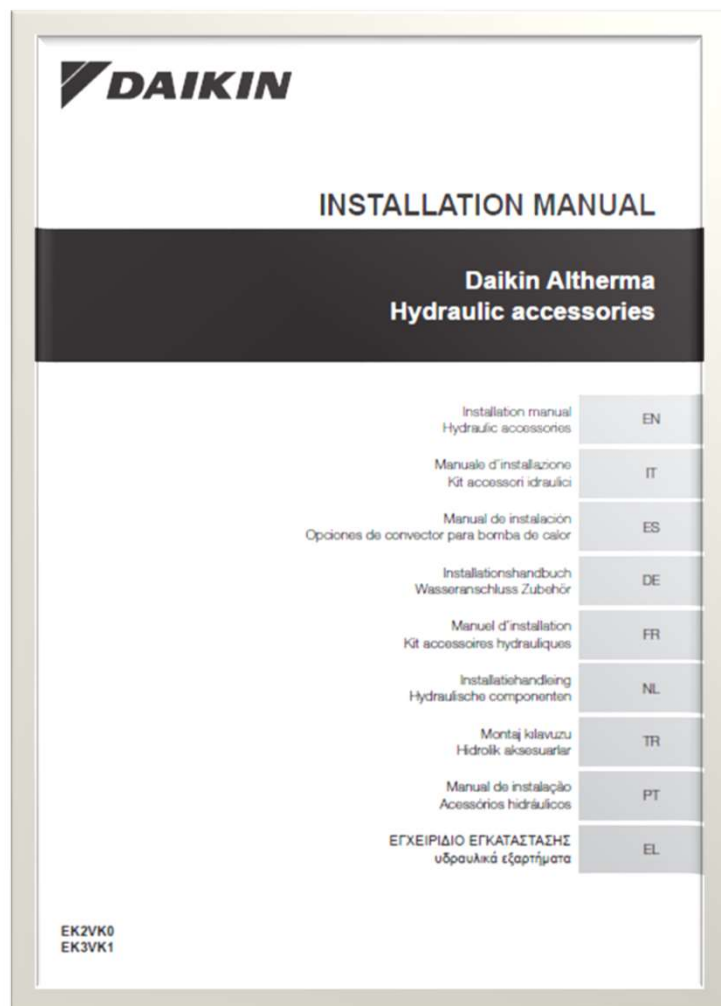

Language	Packed with unit (STC)	Only online (DOD)
English	STC	-
Italian	STC	-
Spanish	STC	-
German	STC	-
French	STC	-
Dutch	STC	-
Turkish	STC	-
Portuguese	STC	-
Greek	STC	-
Danish	-	DOD
Swedish	-	DOD
Norwegian	-	DOD
Finnish	-	DOD
Czech	-	DOD
Croatian	-	DOD
Hungarian	-	DOD
Polish	-	DOD
Romanian	-	DOD
Slovenian	-	DOD
Estonian	-	DOD
Bulgarian	-	DOD
Lithuanian	-	DOD
Latvian	-	DOD
Slovak	-	DOD

2.9. Country compliance

Country compliance: Sales region

List of countries	
Austria	Liechtenstein
Belgium	Lithuania
Bulgaria	Luxembourg
Croatia	Malta
Cyprus	The Netherlands
Czech Republic	Norway
Denmark	Poland
Estonia	Portugal
Finland	Romania
France	Slovakia
Germany	Slovenia
Greece	Spain
Hungary	Sweden
Ireland	Switzerland
Italy	Turkey
Latvia	United Kingdom

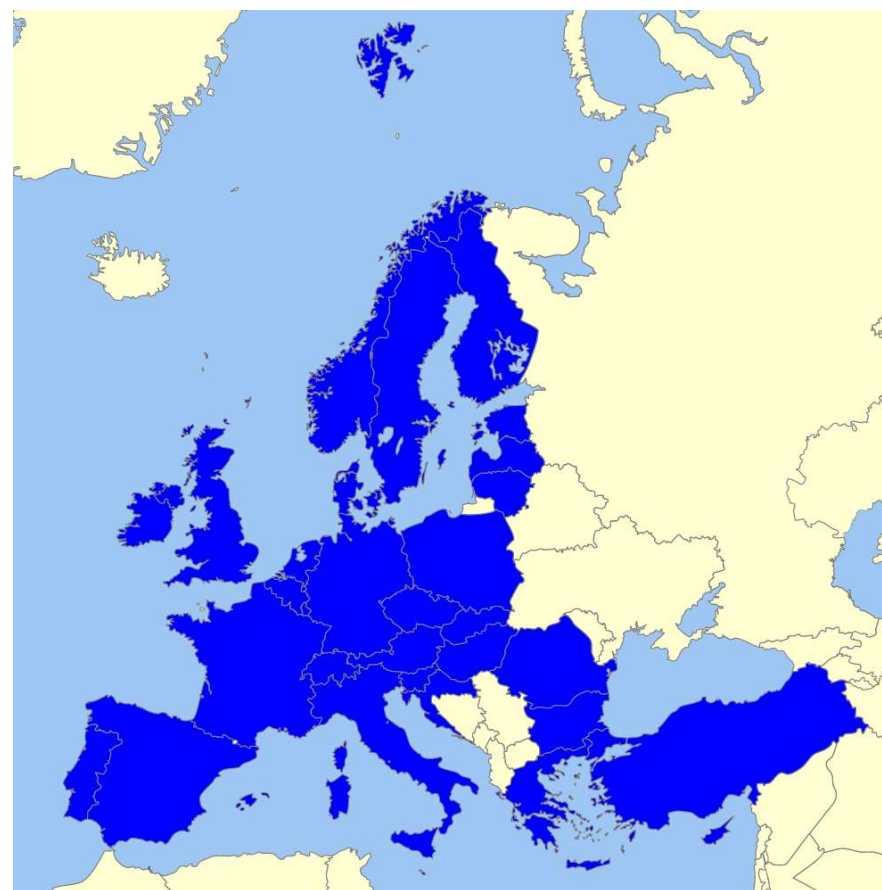

2.10. Spare Parts

Spare parts: Exploded view

FWXV(10/15/20)ATV3

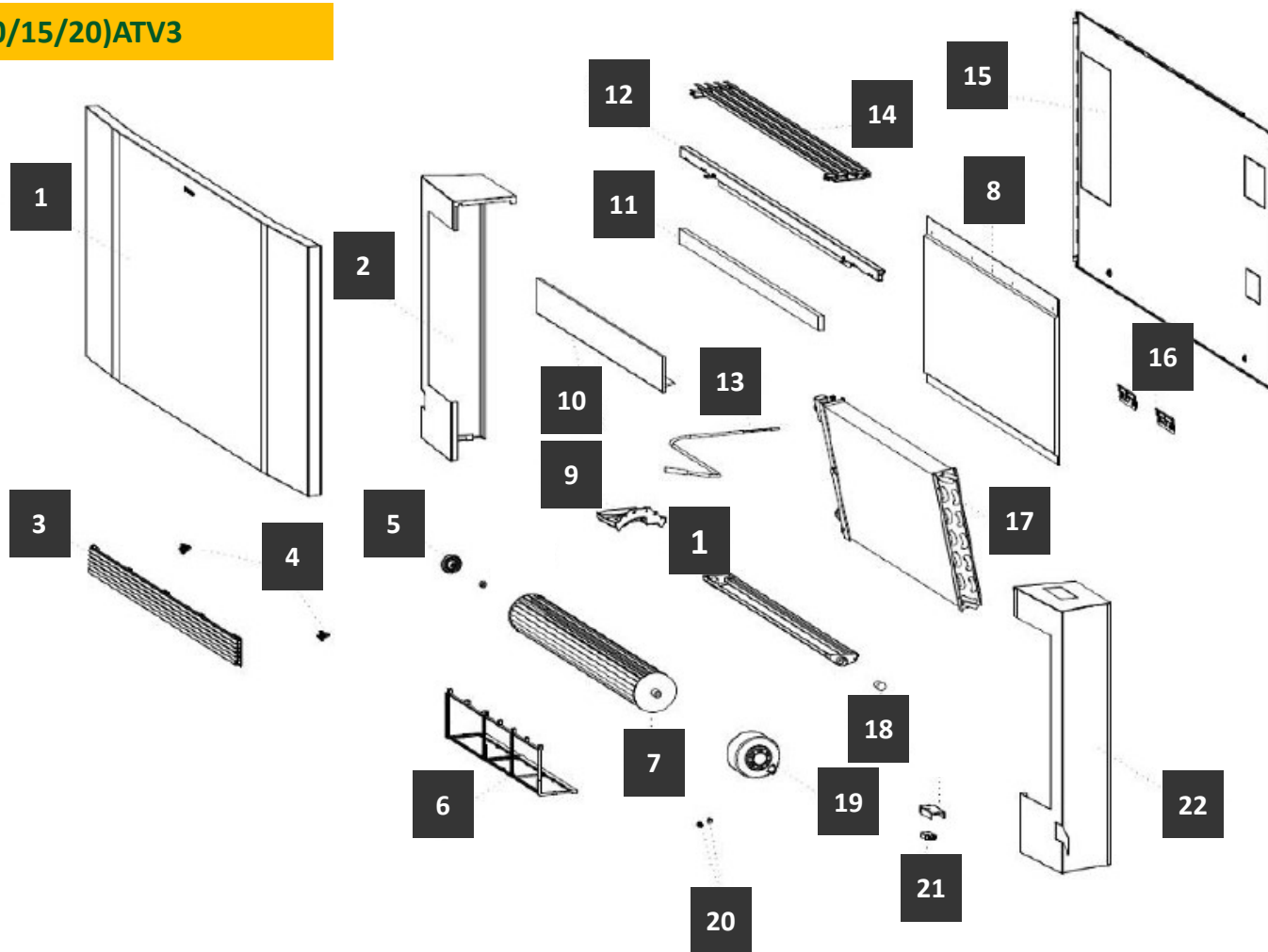

N°	Description
1	Front panel
2	Left metal side – RAL9003
3	Front grill assembly RAL9003
4	Plastic hooks for grid fixing
5	Fan elastic holder
6	Filter
7	Tangential fan
8	Back insulator
9	Side condense drain pan
10	Battery superior isolation
11	Upper front crosspiece insulator
12	Back crosspiece assembled
13	Water probe 70cm 0kOhm
14	Short silver upper grill
15	Rear cover mod
16	Wall bracket
17	Water coil
18	Central condense drain pan plug D
19	Motor DC inverter
20	Screw gomet
21	Mircroswitch
22	Right metal side – RAL9003

Spare parts: Exploded view

EK3VK1

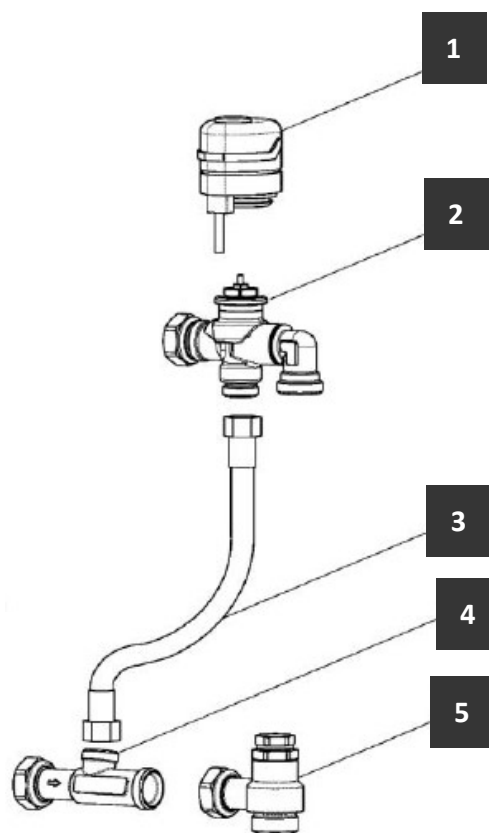

N°	Description
1	Thermoelectric valve drive
2	3 way diverter valve with swivel
3	Flexible tube L23 F-F 1/2"
4	3 way outlet union
5	Adjustable lockshield

EK2VK0

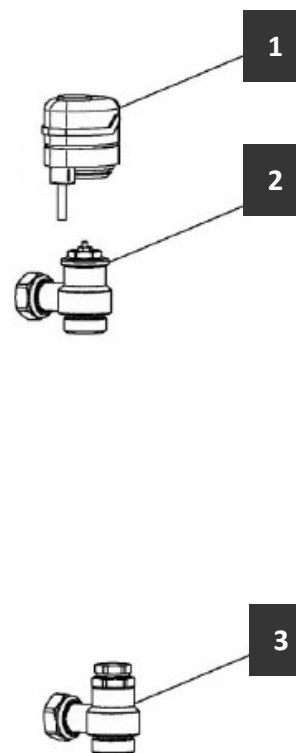

N°	Description
1	Thermoelectric valve drive
2	Valve body
3	Adjustable lock shield

Spare parts: Exploded view

EKRTCTRL1

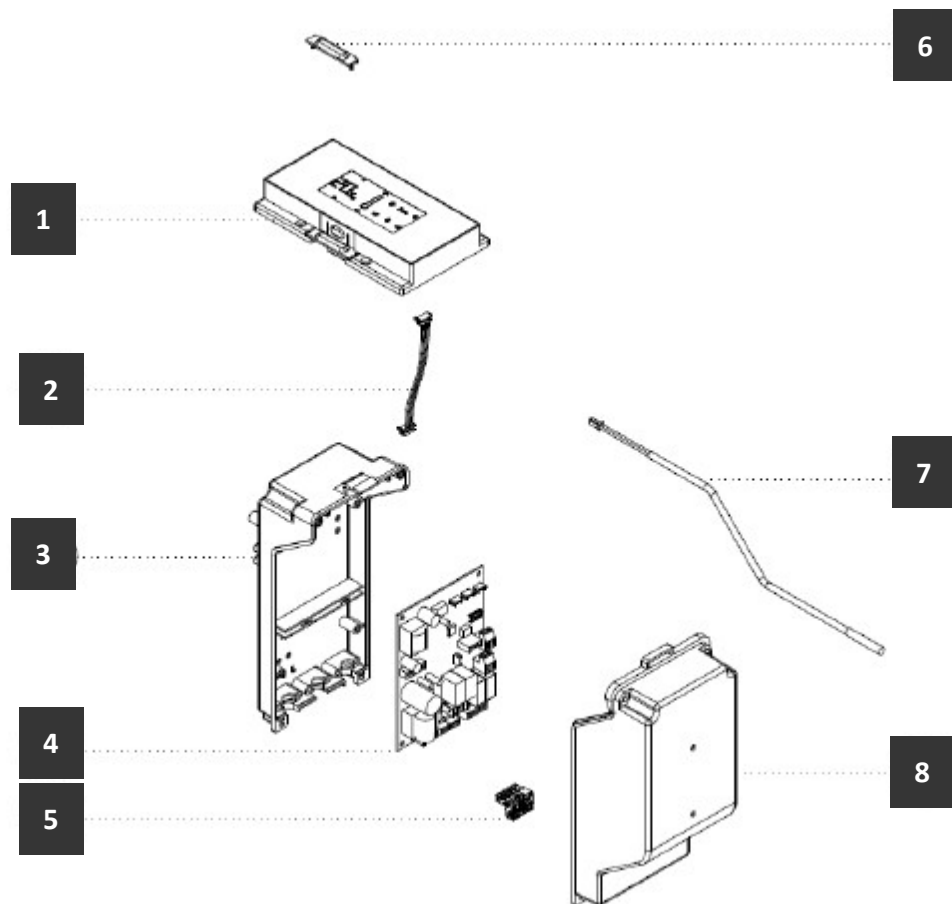

N°	Description
1	Control panel with capacitive display
2	4 pole connection cable 60cm
3	Electronic board box with bridge
4	Electronic board INN-FR-B30
5	4 poles female terminal board
6	Plastic covers
7	Air probe/Water NTC 10kohm – 70cm
8	Card cover

Spare parts: Exploded view

EKRTCTRL2

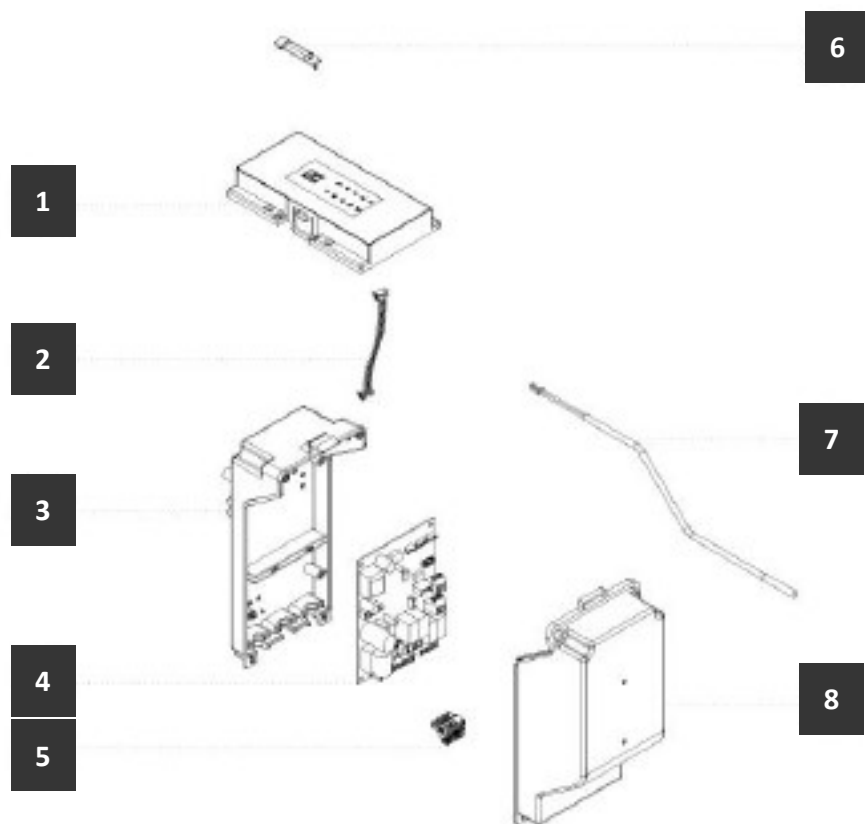

N°	Description
1	Display
2	4 pole connection cable – 60cm
3	Electronic box with bridge
4	Electronic board DC INN-FR-B20
5	Morsett. Femm. 4 green powels
6	Cover for controls with display
7	Air water probe 80cm 10Kohm
8	Electronic board with POPP.

Spare parts: Exploded view

EKWHCTRL0

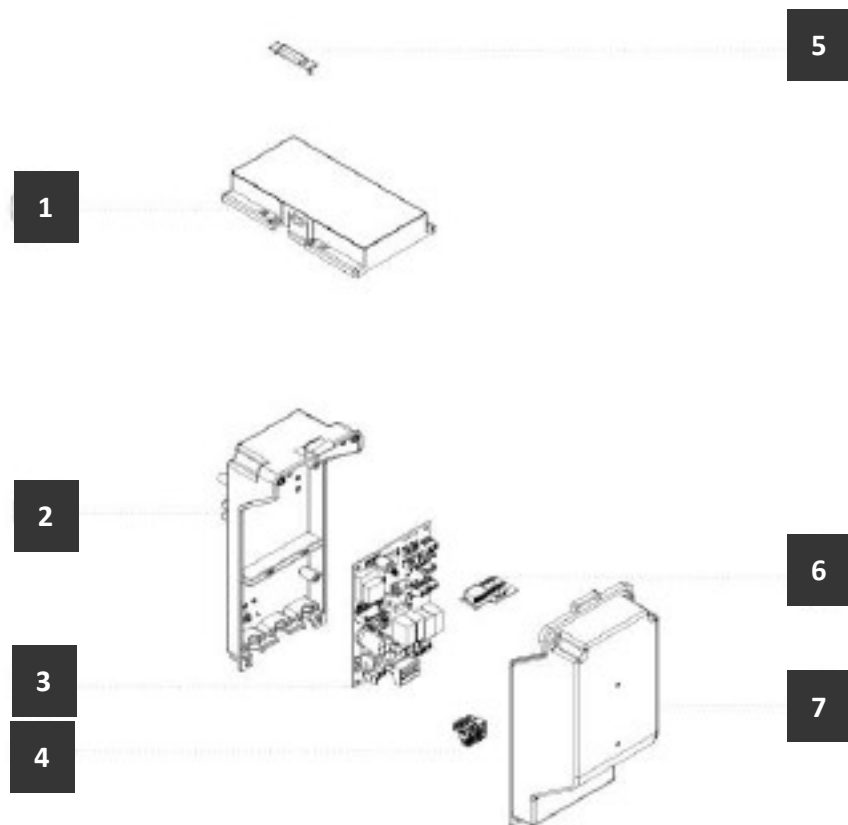





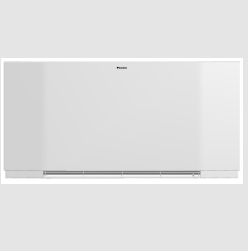

N°	Description
1	Valve cover
2	Electronic board box with bridge
3	Electronic board INN-FR-B30
4	Morsett. Femm. 4 green powels
5	Plastic screw cover
6	Serial connection board INN-FR-RS1
7	Electronic board cover with popp.

2.11. Competitive landscape



Specs comparison

	DAIKIN HPC	AERMEC Omnia HL	Galetti FLAT S	Galetti ART-U	Atlantic Panama	Jaga Aurora	Jaga Briza	
								
Lineup (HC@45 – medium fan speed)	3 models 1,63 – 3,05	4 models 0,73 – 2,42 kW	4 models 1,07 – 3,42 kW	5 models 0,73 – 3,07 kW	3 models 0,5 – 1,9 kW	4 models / 2P 0,4 – 1,0 kW	4 models 0,7 – 2,5 kW	
Dimensions (H x W x D) - mm	Min: 601 x 999 x 135 Max: 601 x 1399 x 135	Min: 600 x 640 x 93 Max: 623 x 1200 x 93	Min: 571 x 820 x 170 Max: 571 x 1160 x 170	Min: 609 x 711 x 101 Max: 609 x 1402 x 101	Min: 678 x 635 x 157 Max: 678 x 920 x 157	Min: 525x600x110 Max: 525x1200x110	Min: 550 x 520 x 117 Max: 550 x 1220 x 160	
Outlook	Zone 1	○	○ / Δ	○	○	◎	○ / ◎	
	Zone 2	◎	X	X	Δ	Δ	◎	○
	Zone 3	◎	X	X	Δ	Δ	◎	○
Sound level (power) – M speed	Min: 43 Max: 44	Min : 37 dBA Max: 43 dBA	Min: 35 dBA Max: 42 dBA	Min : 44 dBA Max: 47 dBA	Min : 29 dBA Max : 31 dBA	Min: 30 dBA Max: 30 dBA	Min; 34 dBA Max: 39 dBA	
Sound pressure (2,5m)) L speed	Min: 34 at 1 m Max: 35 at 1m	Min : 23 dBA Max: 27 dBA			23 dBA		Min : 21 dBA Max: 26 dBA	
Product finishing and quality image	HIGH	MEDIUM	MEDIUM	(HIGH)	MEDIUM	HIGH	HIGH	

2.12. Q&A

cooling valve does not open when in cooling mode, how can I solve it?

if you have a 3-way valve connected to the unit and it does not open in cooling, then you need to set dip switch D from off to on and repower the unit.

What would happen if the CP and S1 (GRID) connector are to be closed?

Concerning GRID and CP contact.

It is not the purpose to use this contacts. They should be left as they are.

But if you change, this will happen:

1. Closing CP contact:
 - The HPC will go in stand-by,
 - Display will be turned off and at the pressure of any key symbol flashes
 - The valve close.
2. Open the GRID contact:
 - on the display appears "Gr"
 - The valve close
 - The fan stops

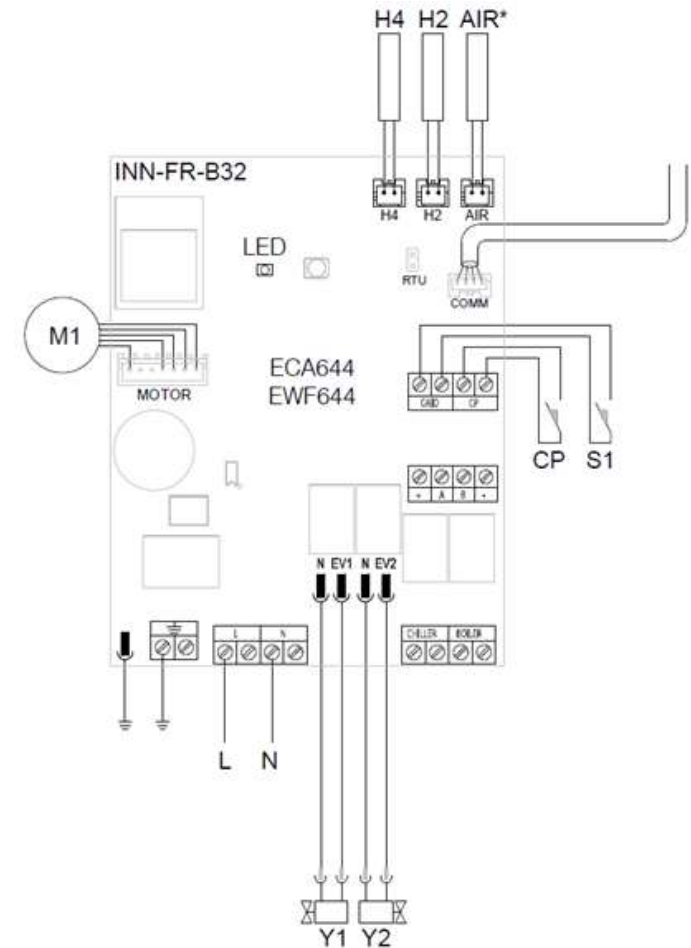

S1 Grid safety micro switch => standard closed

CP Presence input sensor (NO contact) => standard open

Is there a difference in parts between standard hydraulic connection (left) and right-hand side connection for the FWXV?

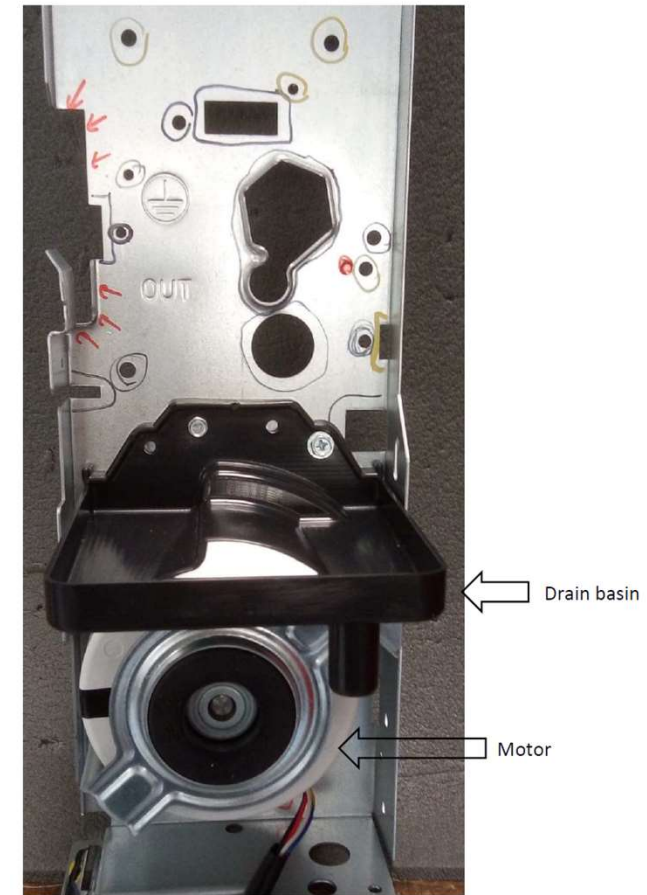
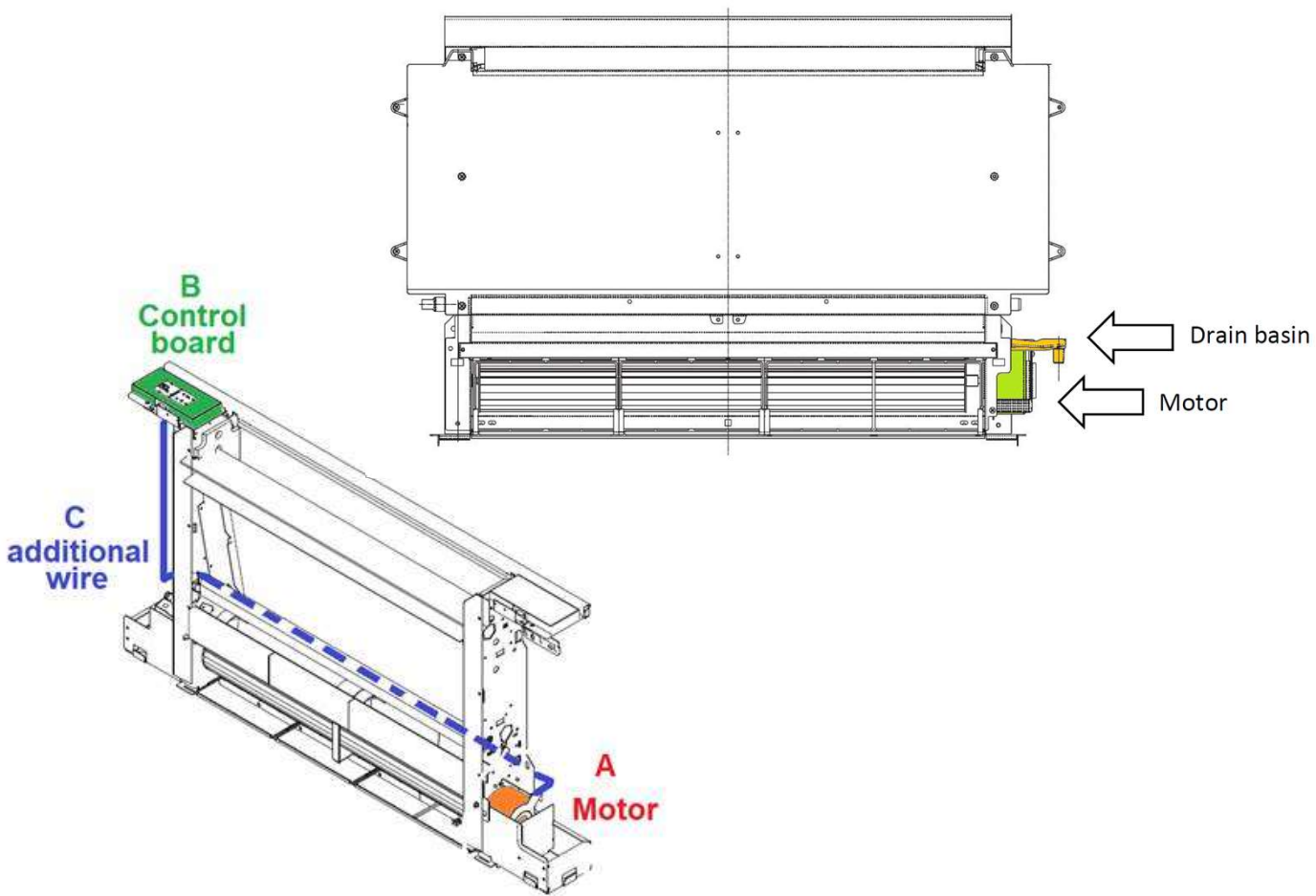

°C/°F SELECTION

By holding the key down for 15 seconds with the panel off, the message "° C" (Celsius) will flash on the panel, by pressing the key again the message changes to "° F" (Fahrenheit), wait 10 seconds the panel switches off with the configuration applied, or press the (switch off) key to save and exit.

For the FWXT-ATV3C

The procedure works only through the unit's display. In this case is the lower arrow under the thermometer symbol. (it cannot be done with the remote controller)

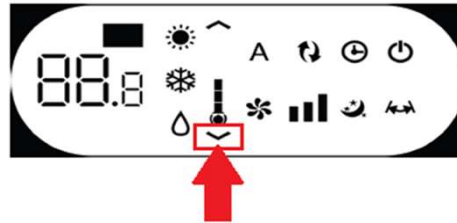

What is Hotel Lock Function and how to activate it?

Pressing air fresh button over 15 seconds (from 20170219 display software), the digital LED will show "ds" or "En". When select "ds", means keeping normal operation, if "En" select, means hotel application function activated to reduce the touch screen selection only to for cooling, heating and fan speed, and the set point temperature selection reduced only in the range from 22 to 28 in cooling and from 16 to 24 in heating.